



# Detail Drawing Standards Manual

September 4, 2018



# 1 Contents

|      |                                    |    |
|------|------------------------------------|----|
| 2    | General Application .....          | 6  |
| 3    | Base (Title Block).....            | 6  |
| 4    | Dimensions .....                   | 10 |
| 4.1  | Dimension Variables .....          | 11 |
| 5    | Stationing.....                    | 11 |
| 5.1  | Union Pacific Stationing .....     | 12 |
| 5.2  | Equations.....                     | 13 |
| 6    | Scale.....                         | 13 |
| 7    | Layers .....                       | 14 |
| 8    | Sheet footage .....                | 14 |
| 9    | Text Settings.....                 | 14 |
| 10   | Leader and Arrow .....             | 15 |
| 11   | Linetype Scale .....               | 15 |
| 12   | LISP Routines.....                 | 16 |
| 13   | Notes .....                        | 16 |
| 14   | State Change.....                  | 17 |
| 15   | Towns .....                        | 17 |
| 16   | Section.....                       | 17 |
| 17   | Townships.....                     | 18 |
| 18   | Range .....                        | 19 |
| 19   | City Limits .....                  | 19 |
| 19.1 | City Limits: .....                 | 19 |
| 19.2 | Township Limits: .....             | 20 |
| 20   | County Change.....                 | 20 |
| 20.1 | County Change: .....               | 20 |
| 21   | Field Requirements .....           | 20 |
| 21.1 | Road and Track Widths.....         | 20 |
| 21.2 | Angled Roads .....                 | 20 |
| 21.3 | Curvature of Tracks and Spurs..... | 21 |
| 21.4 | Stationing and Offsetting .....    | 21 |
| 21.5 | Photographs.....                   | 21 |
| 21.6 | Corrections.....                   | 21 |
| 22   | Bike Path .....                    | 21 |
| 23   | Bridges.....                       | 22 |

---

|        |   |    |
|--------|---|----|
| 23.1   | Drawing Requirements for Bridge Details.....                                | 22 |
| 23.1.1 | Elevation View .....  | 22 |
| 23.1.2 | Plan View.....  | 22 |
| 23.1.3 | Scale.....  | 22 |
| 23.1.4 | GSP Placement .....   | 22 |
| 23.1.5 | Details.....  | 23 |
| 23.1.6 | Stationing.....   | 24 |
| 23.1.7 | End .....   | 24 |
| 24     | Canals.....   | 24 |
| 24.1   | Canals without culverts .....   | 24 |
| 24.2   | Canals with Culverts .....  | 25 |
| 25     | Rivers.....   | 25 |
| 26     | Roads .....   | 26 |
| 27     | Cut and Restore.....  | 27 |
| 27.1   | Example of Cut & Restore with BSP.....                                      | 27 |
| 27.2   | Example of BSP within the Cut & Restore .....                               | 28 |
| 28     | Culverts.....   | 28 |
| 29     | Directional Bores .....   | 29 |
| 29.1   | Drawing instructions for Directional Bore Details for Final As-Builts ..... | 29 |
| 29.2   | Examples of directional bore details for As-Builts .....                    | 30 |
| 30     | PVC Placement .....   | 32 |
| 31     | Buried Service Pipe (BSP) .....   | 32 |
| 31.1   | BSP Placement.....  | 34 |
| 32     | HDPE Bore .....   | 36 |
| 33     | HDPE Configurations .....   | 38 |
| 34     | Handholes.....  | 39 |
| 35     | Manholes .....  | 39 |
| 35.1   | Using Tables .....  | 40 |
| 36     | Aerial Build.....   | 41 |
| 37     | Buildings .....   | 42 |
| 38     | Building Access Agreement Drawing Requirements.....                         | 43 |
| 39     | Blocks .....  | 45 |
| 39.1   | ARP .....   | 45 |
| 39.2   | Arrow Head .....  | 45 |
| 39.3   | Boxpole .....   | 45 |
| 39.4   | Bridge .....  | 45 |

---

---

|       |                                  |    |
|-------|----------------------------------|----|
| 39.5  | Cable .....                      | 46 |
| 39.6  | Caution .....                    | 46 |
| 39.7  | Chevron .....                    | 46 |
| 39.8  | City Limits .....                | 46 |
| 39.9  | County .....                     | 47 |
| 39.10 | Bore Cover .....                 | 47 |
| 39.11 | Culvert .....                    | 47 |
| 39.12 | Directional Bore Detail .....    | 47 |
| 39.13 | Text .....                       | 47 |
| 39.14 | Railroad Equations .....         | 48 |
| 39.15 | Fire Hydrants .....              | 48 |
| 39.16 | Guardrails .....                 | 48 |
| 39.17 | Fiber Markers .....              | 49 |
| 39.18 | CenturyLink Owned Handhole ..... | 49 |
| 39.19 | Other Handholes .....            | 50 |
| 39.20 | Matchline .....                  | 50 |
| 39.21 | Manhole .....                    | 52 |
| 39.22 | Milepost .....                   | 52 |
| 39.23 | North Arrow .....                | 53 |
| 39.24 | Railroad Objects .....           | 53 |
| 39.25 | Pole .....                       | 53 |
| 39.26 | Parallel Objects .....           | 54 |
| 39.27 | Pedestal .....                   | 54 |
| 39.28 | Point of Intersection .....      | 55 |
| 39.29 | Point of Switch .....            | 55 |
| 39.30 | Regen Sites .....                | 55 |
| 39.31 | Retaining Wall .....             | 56 |
| 39.32 | Baseline .....                   | 56 |
| 39.33 | Right of Way .....               | 56 |
| 39.34 | Leader .....                     | 57 |
| 39.35 | Stations .....                   | 57 |
| 39.36 | Trees .....                      | 57 |
| 39.37 | Railroad Track .....             | 58 |
| 39.38 | Slopes .....                     | 58 |

---

|       |  |    |
|-------|--|----|
| 39.39 | Utility Lines Overhead/Underground ..... | 59 |
| 39.40 | Valve .....                              | 59 |
| 39.41 | Reference Point.....                     | 59 |
| 39.42 | Vents .....                              | 59 |
| 39.43 | Val-Map Milepost.....                    | 60 |
| 40    | Parcall Block .....                      | 60 |
| 41    | Objects.....                             | 61 |
| 42    | Plotting.....                            | 62 |
| 42.1  | Plot Settings (Model Space).....         | 63 |
| 42.2  | Plot Settings (Paper Space) .....        | 64 |
| 43    | QA Quality Assurance Checklist.....      | 64 |
| 44    | Revisions .....                          | 66 |
| 45    | Help .....                               | 66 |
| 46    | Abbreviations.....                       | 66 |
| 47    | Glossary.....                            | 70 |
| 48    | References .....                         | 74 |
| 49    | Version History .....                    | 75 |

## 2 General Application

CenturyLink requires all Outside Plant designs (engineering/construction and final as-builts) to be created in an **AutoCAD 2014 or Newer** format using **UTM83** coordinate systems in US Survey Foot units. CenturyLink has created design standards including blocks, line types, and plot styles that are to be used in every project. The standards will not only ensure consistency in our projects but are also time savers that will help with accuracy and legibility. All CenturyLink outside plant designs must utilize these standards. This is for engineering/construction prints and as well as final As-built.

**For any questions, missing data, program issues and or not sure what to do, send email to AskOSPDesign@CenturyLink.com**

## 3 Base (Title Block)

Start in the upper left corner of the base:

Overall City, State (write out state) “Direct-A” Block

Example:

← DENVER, COLORADO

Block “R1” - Goes in between the From overall and the county block at the top of the base.

Cable Type (write out name) - Fiber Count

Reel # (use all twelve digits when given)

Span Letter- City, State - City, State (abbreviate the state)

^ = space

Example:

CABLE^TYPE^TRUEWAVE^~^96  
REEL^#^880122921501  
SPAN-A^DENVER,^CO^^ CASTLE ROCK,^CO

Block “R2” - Goes in between the county block and to overall at the top of the base.

Only used on drawings with splice points – Must remove from title block if no splice

Cable Type (write out name) - Fiber Count

Reel # (use all twelve digits when given)

Span Letter- City, State - City, State (abbreviate the state)

County, State (write out State, see the examples below) “County” Block

---

**Only County -**

County name^County,^State(write out)

Example: ADAMS COUNTY, COLORADO

**Only County Change -**

County name/County name^County,^State(write out)

Example: ADAMS/JEFFERSON COUNTY, COLORADO

**County and State Change -**

County name^County,^State(abbr.)/County name^County,^State(abbr.)

Example: SIERRA COUNTY, CA/NEVADA COUNTY, NV

**County with a city or town-**

County name^County

City name,^State(write out)

Example:

ADAMS COUNTY  
BRIGHTON, COLORADO

**County with a city or town change -**

County name^County

City name,^State(abbr.)/City name,^State(abbr.)

Example:

ADAMS COUNTY  
BRIGHTON, CO/THORNTON, CO

**Overall City, State (write out state) “Direct-B” Block**

Example:

EL PASO, TEXAS

**“TB-PPROJECT” Block**

**North Arrow** – “NAROW” Block - Ensure that the arrow is pointing in the right direction based on the direction of drawing

. (the direction of the arrow should come from your model space.

**Project #** - Put the overall project number here not the segment project number, the segment project number is use for billing of your time only.

**Segment / Span** - Indicates the segment # & the span letter information.

---

Example: SEGMENT: 3/SPAN^J  
**For a segment change -** SEGMENT: 3/4^SPAN^J  
**For a span change -** SEGMENT: 3^SPAN^J/K

Below the segment # and span letter is the segment To and From information. Segment City, State to Segment City, State (abbreviate the state). If there is not a segment for the project use the Span City, State to Span City, State.

This should look like the following in the base

Example: CITY,^STATE(ABBR.)  
TO  
CITY,^STATE(ABBR.)

**Company Logo** - “TB-LOGO” Block (use the correct block based on company)

- Use correct base for the company that owns the project
- TB-LOGO for ICTL
- TB-LOGO\_LVLT for fLVLT

**Revisions** - Only to be filled on a project by project basis. You will be informed on when and what information to put, otherwise leave blank.

**Property Note** - “tb-legal” block - Make sure the company block named in note matches the Logo

- Tb-legal for ICTL
- Tb-legal\_LVLT for fLVLT

**One-Call** – “TB-811” Block

- TB-811 for ICTL
- TB-811\_LVLT for fLVLT

**As-Built dates** – “TB-ASBUILT’ Block

**Scale** – “TB-SCALE” Block

B (size of dwg) 1”^=^100’  
D (size of dwg) 1”^=^50’

**MP to MP and DWG. #** - “TB-DWGNUM” Block

Put in milepost you are in and what milepost you are headed towards.

**Drawing number** -

Normally the drawing number is the mile post number you are in and the sheet you are on within that mile. Example: 186-3. For projects that run high milepost to low milepost, you would be in the low milepost. Example MP 197 to 196 you are in MP 196.





## 4 Dimensions

Dimensions should be noted at the following locations

- R/W At the beginning and end of a sheet
  - At R/W changes
- Conduit
  - At the beginning and end of BSP, GSP, PVC, DB's, concrete encased & cut & restore placements.
  - All deviations of conduit
  - At the beginning and end of a sheet unless the deviation spans two sheets, then at the beginning and end of the deviation
- Track At the beginning and end of a sheet
  - Where the tracks deviate when you have two or more tracks
- Roads At the beginning and end of a sheet
  - Where the roads deviate.

Examples of acceptable dimension:

(Do not modify the dimension style, move the dimension text only when needed.)

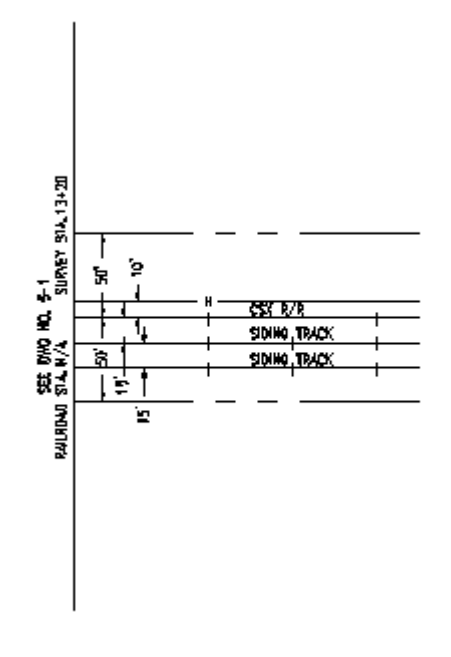

**Note:** Dimensions will be based upon and drawn from a pre-determined base line.

Tip of dimension arrowhead needs to point to a line not a space within that line.

**Do not ever** break the R/L line, BSP, GSP, PVC, DB's, concrete encased, cut & restore, track or the baseline for the dimensions

## 4.1 Dimension Variables

Running “Rep10, Rep20, Rep40, Rep50, Rep60, Rep100” will set all these up for you and adjust what is needed depending on the scale of your drawings. Which lisp you run routine depends on the drawing scale to set these variables. Make sure you Set the scale as described in the AutoCAD Setup Manual

|                                 |        |
|---------------------------------|--------|
| DIMAFIT                         | 0      |
| DIMALT                          | 0      |
| DIMASO (DIMASSOC '04 and higher | 1      |
| DIMASZ                          | .01    |
| DIMCEN                          | 0.1    |
| DIMCLRD                         | 256    |
| DIMCLRE                         | 256    |
| DIMCLRT                         | 256    |
| DIMDEC                          | 0      |
| DIMDLE                          | 0      |
| DIMDLI                          | 0      |
| DIMEXE                          | 0.2    |
| DIMEXO                          | 0.1    |
| DIMGAP                          | 0.1    |
| DIMLFAC                         | 1      |
| DIMLIM                          | 0      |
| DIMLUNIT                        | 2      |
| DIMPOST                         | ""     |
| DIMRND                          | 0      |
| DIMSAH                          | 0      |
| DIMSE1                          | 1      |
| DIMSE2                          | 1      |
| DIMSTYLE                        | Qwest  |
| DIMTAD                          | 0      |
| DIMTFAC                         | 1      |
| DIMTIH                          | 0      |
| DIMTIX                          | 0      |
| DIMTMOVE                        | 0      |
| DIMTOH                          | 0      |
| DIMTOL                          | 0      |
| DIMTSZ                          | 0      |
| DIMTVP                          | 0.1    |
| DIMTXT                          | 0.1    |
| DIMTXSTY                        | ROMAND |
| DIMZIN                          | 0      |
| INSUNITS                        | 0      |
| INSUNITSDEFSOURCE               | 0      |
| INSUNITSDEFTARGET               | 0      |

## 5 Stationing

---

Do not abbreviate except for:

|     |     |
|-----|-----|
| R/W | O/S |
| R/R | W/  |
| STA | &   |

The station callout should be located 100 feet past the furthest R/W Station Callouts should be perpendicular to the baseline. The following are some examples of station callouts:

STA 0+75 (2) CMP CULVERTS

STA 1+20 BEGIN 5" BSP & R/L CHANGE

STA 2+10 CCLC HANDHOLE 15' O/S

STA 2+25 R/R SIGN 35' O/S

STA 2+95 R/L CHANGE

STA 3+00 BEGIN DIRECTIONAL

BORE & R/L CHANGE

## 5.1 Union Pacific Stationing

The Union Pacific R/R requires Railroad station at the follow areas:

Begin & End of (BSP, Bores – Steel, HDPE, & Directional)

Bridges

Culverts

Edge of Road & Overpasses

Handhole / Manholes

Point of Switch

R/L Changes

R/R Designations (R/R Battery Box, R/R Crossing etc)

To figure the stationing, please contact a representative from the CenturyLink Communications Corporation, LLC Cad Department.

## 5.2 Equations

Equations are used to identify change in stationing due to a baseline change, running line change and/or merging of two different roads or railroads.

Examples:

|  |
|--|
| $\text{EQUATION } \frac{XX+XX}{XX+XX}$ <p style="text-align: center;">EQL</p>        |
| $\frac{XX+XX}{XX+XX} \text{ EQUATION}$ <p style="text-align: center;">EQR</p>        |
| $\text{R/R EQUATION } \frac{XX+XX}{XX+XX}$ <p style="text-align: center;">RREQQL</p> |
| $\frac{XX+XX}{XX+XX} \text{ R/R EQUATION}$ <p style="text-align: center;">RREQQR</p> |

## 6 Scale

CenturyLink Drawings scale standard is:

For Railroad build = 1" = 100'

For Road Build = 1" = 50'

Use of any other scale should only be used as an exception, in very congested areas where all data will not fit on the drawings. Drawings done to a different scale other than stated above that are not congested will be rejected unless otherwise approved. Contact the RGFM Team. for questions at [AskOSPDesign@CenturyLink.com](mailto:AskOSPDesign@CenturyLink.com)

| CenturyLink Communications Corporation, LLC Standard Scales |           |           |          |          |          |          |          |          |                     |
|---|-----------|-----------|----------|----------|----------|----------|----------|----------|---------------------|
| Drawing Scale   | 1" = 200' | 1" = 100' | 1" = 60' | 1" = 50' | 1" = 40' | 1" = 30' | 1" = 20' | 1" = 10' | Paper Space         |
| Block Ins<br>Scale and<br>Line widths                       | 2         | 1         | 0.6      | 0.5      | 0.4      | 0.3      | 0.2      | 0.1      | 0.01                |
| Text Height   | 12.5      | 6.25      | 3.75     | 3.125    | 2.5      | 1.875    | 1.25     | 0.625    | 0.0625              |
| Dim Scale   | 100       | 50        | 30       | 25       | 20       | 15       | 10       | 5        | Same as Model Space |
| Ltscale   | 100       | 50        | 30       | 25       | 20       | 15       | 10       | 5        | Same as Model Space |

## 7 Layers

These Layers should be in your Base Drawing

| Layer Name: | Color:      | Linetype:  | Plottable: |  |
|-------------|-------------|------------|------------|--|
| 0           | White (7)   | Continuous | Yes        |  |
| BASELINE    | Magenta (6) | Continuous | Yes        |  |
| BORDER      | Yellow (2)  | Continuous | Yes        |  |
| CABLE       | Yellow (2)  | Continuous | Yes        |  |
| CULVERTS    | Cyan (4)    | Continuous | Yes        |  |
| DEFPOINTS   | White (7)   | Continuous | Yes        |  |
| DIM         | Red (1)     | Continuous | Yes        |  |
| FENCE       | Green (3)   | Continuous | Yes        |  |
| GUIDELINES  | Grey (8)    | Continuous | No         |  |
| MARKERS     | Magenta (6) | Continuous | Yes        |  |
| MATCH       | Yellow (2)  | Continuous | Yes        |  |
| NOTES       | White (7)   | Continuous | Yes        |  |
| OBJECTS     | Magenta (6) | Continuous | Yes        |  |
| FIBER       | Red (1)     | Continuous | Yes        |  |
| RETWALL     | Red (1)     | Continuous | Yes        |  |
| ROAD        | Blue (5)    | Continuous | Yes        |  |
| ROW         | Blue (5)    | Phantom    | Yes        |  |
| SLOPE       | Brown(33)   | Continuous | Yes        |  |
| TEXT        | White (7)   | Continuous | Yes        |  |
| TITLE       | Magenta (6) | Continuous | Yes        |  |
| TRACK       | Magenta (6) | Continuous | Yes        |  |
| UTILITY     | Green (3)   | Hidden     | Yes        |  |
| VIEWPORT    | Grey (8)    | Continuous | No         |  |

**Note:** No layers shall be modified.

## 8 Sheet footage

Break drawings into no more than 1320' measurements based on a 100 scale.

Note: Sheet to sheet continuity must be kept. All lines must line up from one sheet to the next.

## 9 Text Settings

(100 scaled drawings) REP program with set this to the correct settings depending on drawing scale

Text Settings: Style: Romand  
 Height: 6.25  
 Width: 0.75

(Exception: Main road name parallel to R/L is at a height of 8.00 - Insert block name "RTEXT")

## 10 Leader and Arrow

All leaders and arrows on leaders must point to the objects they are calling out, even if the object must be moved a little for clarity

When calling out items such as bridges, culverts, edge of roads, (things that cross the baseline), the leader and arrow must point to the intersection where the item crosses the baseline.

When calling out running line changes, the leader and arrow must point at the point on the running line that the change occurs. If a dimension for a running line change must be moved for clarity, the leader and arrow should remain pointing to the location where the running line change happened.

When calling out handholes, the leader and arrow must point to the “left” edge of the handhole where the running line and the edge of the handhole intersect. On drawings where the stationing is running right to left the leader and arrow must point to the “right” edge of the handhole where the running line and the edge of the handhole intersect.

The AHD block should be placed on the following features where we do not know where they go.

- R/W
- Utilities
- Tracks
- Fences

Examples:

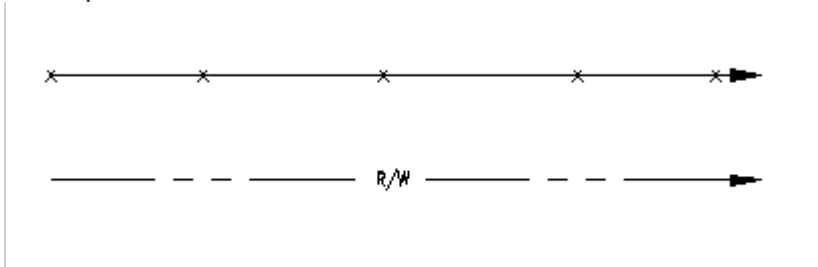

## 11 Linetype Scale

To obtain the correct line type scale & drawing setup, run the REP command.

Example:

| Drawing is at: | Run    |
|----------------|--------|
| 1"= 10'        | REP10  |
| 1"= 20'        | REP20  |
| 1"= 40'        | REP40  |
| 1" = 50'       | REP50  |
| 1" = 60'       | REP60  |
| 1" = 100'      | REP100 |

## 12 LISP Routines

See LISP-Reference\_Manual for a description of approved RGFM programs.

Auto-Lisp routines operate in the same manner as manual CAD drafting but allow for more efficient use of time by automating repetitive tasks. Since the ACAD commands utilized are often the same as those used for operator-driven ACAD, it is sometimes necessary to alter certain variables (I.E. osnap, layer, aperture, and pick box) in an effort to improve performance. When necessary to alter these settings, all RGFM lisp routines, inventory current settings, perform pre-programmed operations, and reset altered variables to original configuration. On occasion, an operator may find his/her settings have changed. This is most often a result of canceling the routine prior to completion. To avoid this condition, it is recommended to allow a routine to run completely as opposed to canceling, then undo the most recent changes and try again.

## 13 Notes

To use the Standard Note program the user will use the “**Note**” from the Drafting Tools section of the OSP-CAD menu see (Menu Overview). If a standard note does not match the users need they can just type in what is needed in the fields of the application each line will only allow 31 characters, If the limit is reached the user will have to go to the next line of the form. This will ensure they are to standards. For more information regarding notes see AutoCAD Setup Instructions

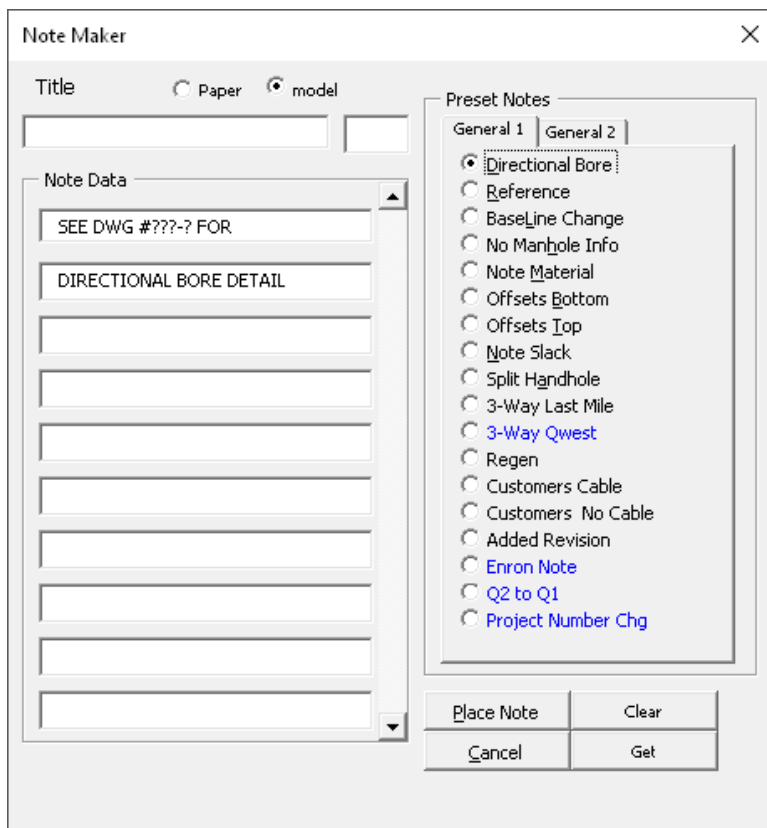



# 14 State Change

Use CITYLIM block  
 Put text as follows -  
 State name (write out)^state line  
 Text is to be put on the side of the line that is in that state  
 Example:



When two changes OCCUR on the same line put one on one end and one on the other.

# 15 Towns

Towns are to be shown in the Base beneath the county information. Same as City

ADAMS COUNTY  
 BRIGHTON, COLORADO

# 16 Section

Below is a diagram showing the split of Section, Township and Range for the parts of the United States.

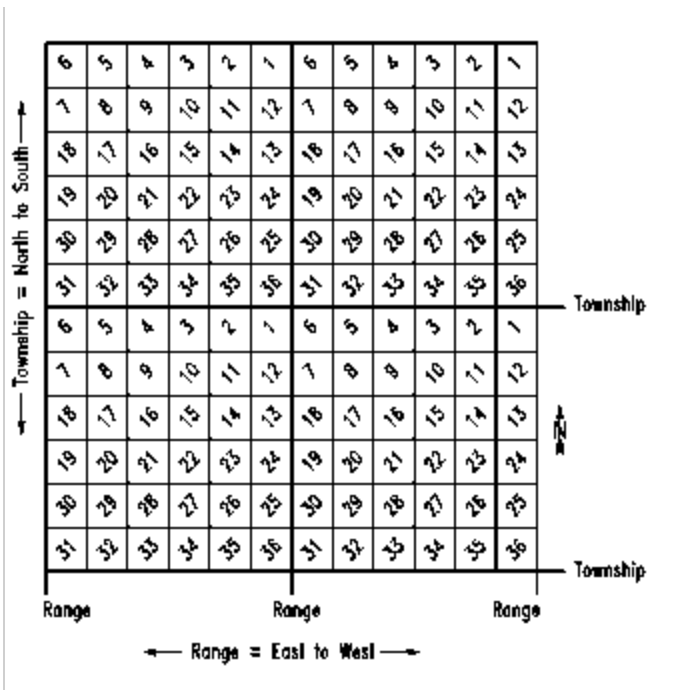



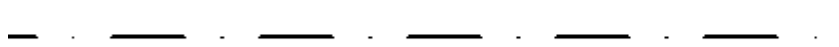



$$\begin{array}{r} \text{R } 32 \text{ E T } 5 \text{ N} \\ \text{R } 33 \text{ E T } 6 \text{ N} \end{array}$$

Section, Township, and Range Change:  $\text{SEC}^{\wedge}\#\text{T}^{\wedge}\#\text{(NorS)}^{\wedge}\text{R}^{\wedge}\#\text{(EorW)}$

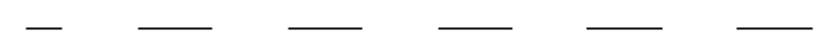
Example:



$$\begin{array}{r} \text{SEC } 1 \text{ T } 7 \text{ N R } 32 \text{ E} \\ \text{SEC } 31 \text{ T } 8 \text{ N R } 33 \text{ E} \end{array}$$

## 18 Range

Use Sect Block

Range Change Only:

Example:

$\text{R}^{\wedge}\#\text{(EorW)}$

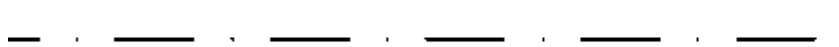



$$\begin{array}{r} \text{R } 32 \text{ E} \\ \text{R } 33 \text{ E} \end{array}$$

Range and Section Change:

Example:

$\text{SEC}^{\wedge}\#\text{R}^{\wedge}\#\text{(EorW)}$





$$\begin{array}{r} \text{SEC } 24 \text{ R } 32 \text{ E} \\ \text{SEC } 19 \text{ R } 33 \text{ E} \end{array}$$

Range and Township Change:

Example:

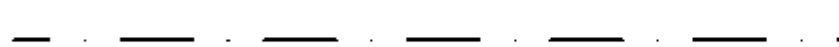
$\text{T}^{\wedge}\#\text{(NorS)}^{\wedge}\text{R}^{\wedge}\#\text{(EorW)}$



$$\begin{array}{r} \text{T } 7 \text{ N R } 32 \text{ E} \\ \text{T } 8 \text{ N R } 33 \text{ E} \end{array}$$

Section, Township, and Range Change:  $\text{SEC}^{\wedge}\#\text{T}^{\wedge}\#\text{(NorS)}^{\wedge}\text{R}^{\wedge}\#\text{(EorW)}$

Example:



$$\begin{array}{r} \text{SEC } 1 \text{ T } 7 \text{ N R } 32 \text{ E} \\ \text{SEC } 31 \text{ T } 8 \text{ N R } 33 \text{ E} \end{array}$$

## 19 City Limits

### 19.1 City Limits:

Use "citylim" block

Place text on the side of block that is within the city limits

Place in text as follows –

Town or City name, ^State(abbr)^City ^Limits

Example:



$$\begin{array}{l} \text{CITY LEFT} \\ \text{CITY RIGHT} \end{array}$$

### 19.2 Township Limits:

Use “citylim” block  
 Place text on the side of block that is within the township limits  
 Place in text as follows –  
 Township^of^Name, ^ State(abbr)  
 Example:



## 20 County Change

### 20.1 County Change:

Use “Citylim” block  
 Add all changes that occur to this line  
 Put in text as follows -  
 County Name^County, State(abbr.)  
 Text is to be put on the side of the line that is in that county  
 Example:

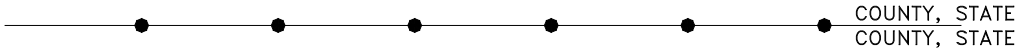

## 21 Field Requirements

The following is a list of items that are required on all drawings.

### 21.1 Road and Track Widths

Stations and widths of roads, sidewalks, and alleys are required. If the width of the road changes from 10 feet wide to 20 feet wide, or the track width changes from 15 feet apart to 18 feet apart, add a station from where the change starts, where the change ends with dimensions every 50 to 100 feet.

### 21.2 Angled Roads

Angled roads should have an estimated angle of the road next to the drawn road.

## 21.3 Curvature of Tracks and Spurs

For roads or tracks that have curvature the start and end stations of the curve as well as dimensions are required. Spurs that leave the area, require 3 stations at 15 to 20 feet apart, depending on how sharp the curve is, so we can give the track an accurate arc.

## 21.4 Stationing and Offsetting

A station and an offset for every object is required. For example; water valves, manholes, buildings, anything that is stationary. Stationing should also always be from Left to Right

Use one baseline for offsets and stationing per project, example: the centerline of a road, the edge of a road or one track. Put a note on the drawing stating where your offsets are being taken from. A note is also required if you are changing baselines. Be sure to list the stations where the change applies. Example: Stations and offsets are being taken from north side edge of road from sta. 13+20 to sta. 15+50. Be consistent with your offset lines. If you're offsetting from one track on this page, don't offset from a different track on the next page. Do not use the proposed running line as a baseline.

## 21.5 Photographs

Try to draw in as much detail for congested areas as possible. Take pictures when more clarity is needed adding notes explaining what you're doing. Be sure to label the pictures.

## 21.6 Corrections

When making corrections be sure to always have your Name, Phone Number and Date included with the drawings.

# 22 Bike Path

Indicate begin and end station numbers. **(Just like a crossing road)**

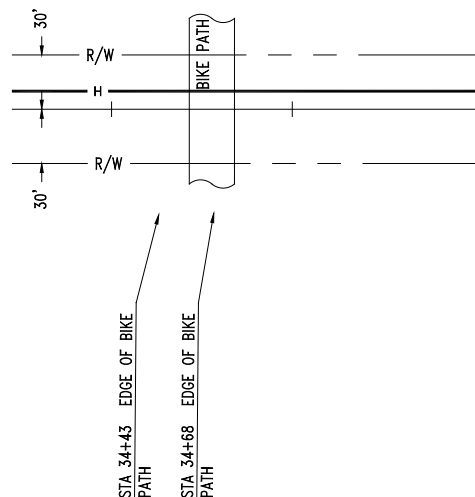

---

## 23 Bridges

### 23.1 Drawing Requirements for Bridge Details

All blocks used to make Bridge detail as described below can be found in the C:\CAD\Blocks

---

#### 23.1.1 Elevation View

1. Begin with a new drawing using the “SAVEAS” command to name file.
2. Use the drawings, notes and pictures from the field to draw the bridge as accurately and as proportionately as possible. Use the difference between the beginning and ending bridge stations to gauge the length of the bridge. Make sure that the height and all objects, excluding the GSP, are proportionate to the length. (Bridge detail files may not always have correct picture or attachment details.)
3. Insert “TRKELEV” or “ENDTRK” depending on whether or not the track is above or below the top of the bridge, this is used to show the track crossing the bridge.
4. Insert and place “RAIL” block when appropriate. This is used to show the handrails placed on many bridges.
5. Draw ground, rivers, roads, etc., only when they are needed to show how the bridge is positioned.

#### 23.1.2 Plan View

1. Project all relevant lines for the beginning and end of the bridge as well as any piers or headwalls down to show their position on the plan view. Some bridges may be at an angle, take this into note. In this case, the projection lines only work for the front view.
2. Insert “TRK”(single track) or “TRK2”(double track) and edit as necessary for track. These are used to show the track crossing the plan view. In cases where these blocks are not long enough, explode them, stretch the lines 2 tracks (4 lines), the centerline, as well as the centerline callouts.
3. The plan view should match the elevation view.

#### 23.1.3 Scale

1. Draw a separate rectangle around both the elevation and the plan view. Change the layer of the rectangles to border layer.
2. Move everything; starting from the bottom left corner of the bottom rectangle, to the coordinates 20,20.
3. Insert BRBASE at coordinates 0,0.
4. Scale the bridges so that they fit within the base drawing area. Leave room for any details that may need to be inserted. It is a good idea to pick out which blocks you need to insert before scaling, this way the page can be filled. Try not to leave large empty areas on the sheet.
5. Insert “PLANV” and “ELEV” and place accordingly. The insertion point for these blocks is the bottom center. These blocks will be inserted to the midpoint on the bottom line of the individual rectangles containing the plan and elevation views.
  - These blocks may need to be exploded then trimmed and or extended as per bridge size.

#### 23.1.4 GSP Placement

1. Draw a polyline across bridge showing (being as proportionate as possible) all R/L changes.

2. Offset the pline 3' on both sides.
3. Cap the ends.
  - If the HDPE enters/exits directly into GSP then extend the center pline out.

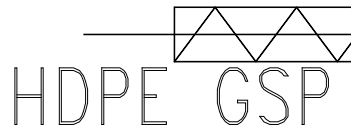

- If BSP is placed at the beginning/end of the GSP then do not extend.

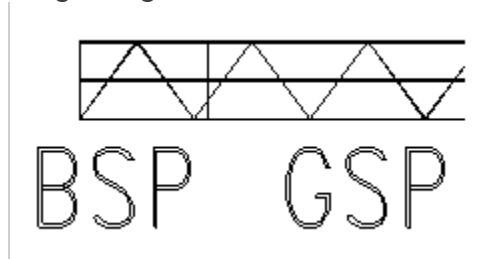

- Insert "ZIG" using the measure command. The distance used for the measure command is 9'.
4. Pan across GSP and make sure ZIGs are rotated and trimmed correctly.
  5. To show the location of expansion joints on the GSP, insert the block "EXJDOT" at the appropriate locations. Repeat these steps (1-5) on both the plan and elevation view.
  6. On the plan view, dimension the pipe, including any and all R/L Changes, off the centerline of the main track.
  7. On the elevation view, only dimension the beginning and the end of the GSP in inches. On the elevation view the dimensions are the depths at which the GSP starts and ends.

### 23.1.5 Details

8. Insert the block detail "CORE" when there is a concrete core bore.
  - 1) "CORE\_S" is used for steel core bores.
    - a) When core bores are placed, it is necessary to insert "SECBB" and place over GSP on plan view where the actual bore is placed.
    - b) On the plan view where the actual Core Bore is, this area of GSP must be turned to solid.
    - c) These blocks, 'CORE, 'CORE\_S' show the standard 5" GSP, however the block will need to be exploded and changed in cases where a different size GSP is used.
9. Insert the blocked detail "EXJ" whenever expansion joints are used on a bridge. You will station the expansion joint when known, if not use N/A for the station.
10. Insert "PSLOC" when pipe straps are used and "BRLOC" for every other type of bracket.
11. These blocks need to be exploded and edited depending on how many attachment locations there are. This block is editable.
12. Insert the appropriate detail blocks to show how GSP is being attached to bridge. Double check to make ensure that the correct block is inserted; some of the blocks are very similar and have only minor changes.

### 23.1.6 Stationing

1. Insert “STA\_BR” for station callouts. All callouts are to be placed on Plan View, except in rare extreme circumstances. (An example of an extreme case would be to show the location of brackets on the vertical accent of a pier, wall, etc...)
2. The following needs to be shown on all bridges. (not necessarily in this order)
  - Begin GSP
  - Begin Bridge
  - Begin Bridge Attachment
    - a) Begin bridge and begin bridge attachment are always the same station,
  - R/L changes (if any)
  - Expansion Joints (if any)
  - Core Bores (if any)
    - a) (1) Call out only the beginning of core bore using measurements in the length of inches. (NOT THE DIAMETER) (i.e. 24” CORE BORE)
    - b) The number of inches will vary from bore to bore, see files for exact lengths.
  - End bridge.
  - End Bridge Attachment.
  - End GSP
  - NOTE : THESE MUST BE SHOWN ON EVERY DETAIL.

### 23.1.7 End

1. Edit base to appropriate information.
2. Edit as-built quarter mile to match bridge detail, very rarely are they correct. It is very important that the two match. However core bore and expansion joint call-outs are not shown on the As-Builts. This should be the only contradiction in stationing between the bridge detail and the As-Builts.

## 24 Canals

### 24.1 Canals without culverts

Indicate a canal as two straight parallel lines perpendicular and or angled to the baseline that extend 25’ past the R/W The description “Canal” is placed between the parallel lines. Do not trim the R/W. Layer = Road. (same for ditches, washes, etc.) 15’ wide if width is unknown.

Example:



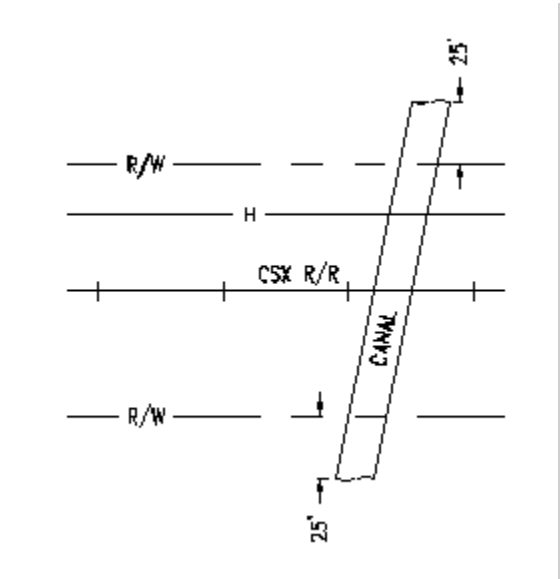

### 24.2 Canals with Culverts

Canals with culverts will have two contour lines that begin at the end of the culvert and continue 25' past the R.O.W. (ditches, washes, etc.)

The description "Canal" is to be placed between these lines.

If an offset is given for culverts scale the culvert block to those offsets.

Example:

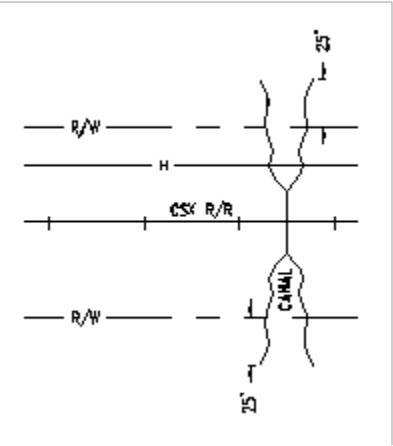

### 25 Rivers

Rivers that parallel the baseline will be shown using (parcall) block.

Layer = Culverts

Example

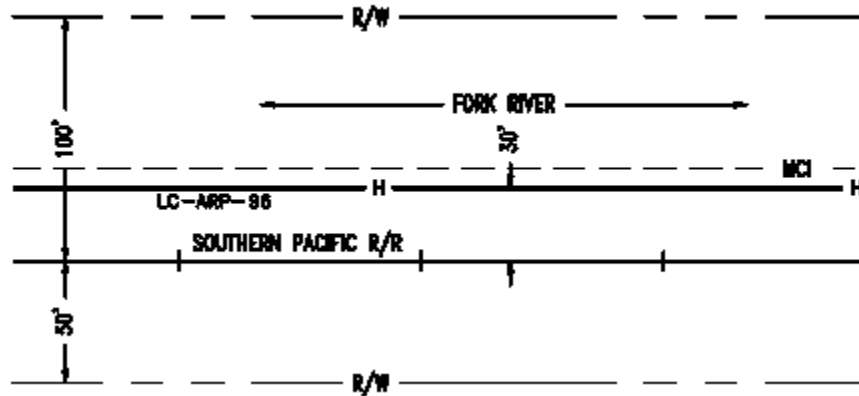

Rivers: Perpendicular river crossings will have two contour lines 25' past the R/W. A few short line segments of water to be shown within the contour lines. Be sure to place the name of this river between the outline. Do not trim the R/W. Layer = Road.

Example:

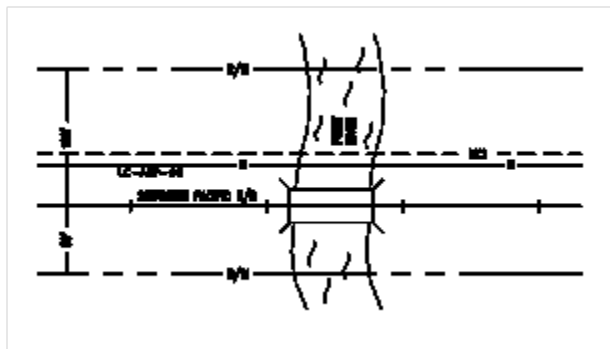

## 26 Roads

Roads that parallel the baseline will be shown using the parcall block.

Layer = Road.

Roads that are perpendicular to that baseline need to extend 25' past r/w on both sides.

There should be centerlines on all roads

Trim R/W on all roads except Overpasses

|             |                  |               |                  |
|-------------|------------------|---------------|------------------|
| Name        | Cad Abbreviation | Name          | Cad Abbreviation |
| Avenue      | AVE              | Interstate 25 | I-25             |
| Boulevard   | BLVD             | Overpass      | OVERPASS         |
| Circle      | CIR              | Place         | PL               |
| Court       | CT               | Road          | ROAD             |
| County Road | CR               | Street        | ST               |
| Highway     | HWY              | Way           | WAY              |
| Parkway     | PKWY             | State Road    | SR               |

Route RT  
 Loop LOOP  
 Example:

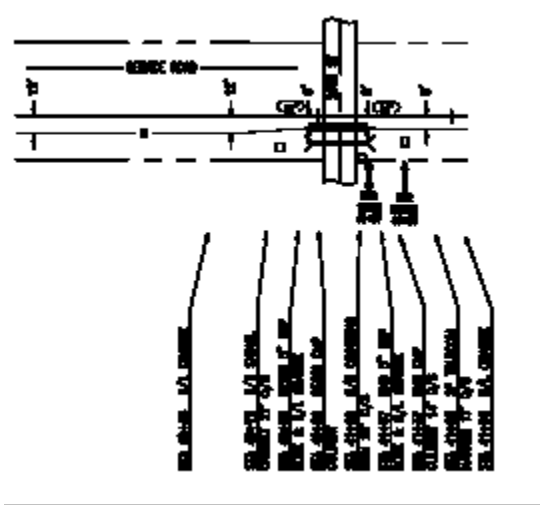

## 27 Cut and Restore

Drawing instructions for cut & restore

### 27.1 Example of Cut & Restore with BSP

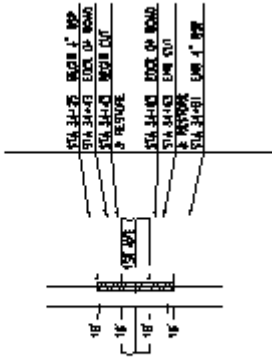

### 27.2 Example of BSP within the Cut & Restore

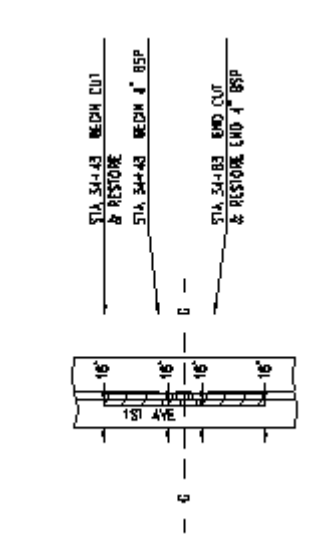

If an as-built drawing has multiple areas of Cut & Restore, the “Stationing” for the beginning and end of the Cut & Restore does not need to be shown and the following note is to be placed on the as-built drawing:

**NOTE:**  
 CUT & RESTORE FROM  
 STA ??+?? TO STA ??+??,  
 STA ??+?? TO STA ??+?? AND  
 STA ??+?? TO STA ??+??

**\*\*Use the Standard Note Program – Accessed by selecting the “NOTE” drop down in the Drafting Tools section of the OPS-CAD Menus. This note does not have existing text so pick any note in the program and change the “Note Data’ to what you need\*\***

## 28 Culverts

Culverts are to be stationed & cadded as documented per redline &/or field information.

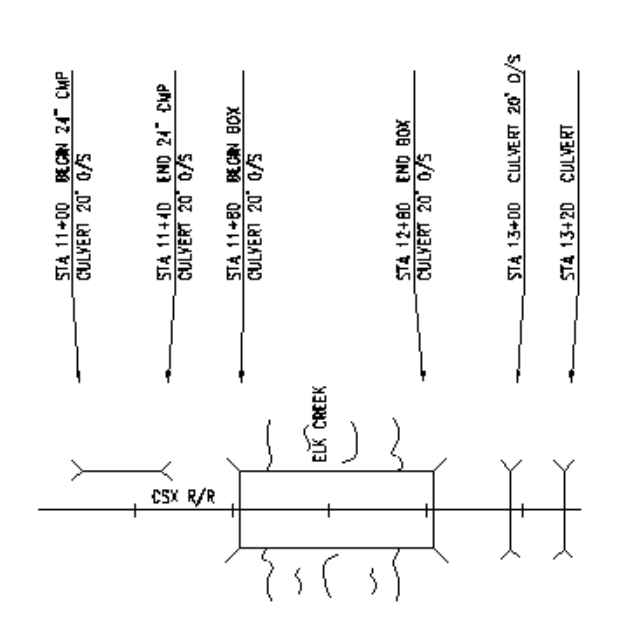

## 29 Directional Bores

Drawing instructions for Directional Bore Details for Engineering/Construction Prints

Insert the DBC, DBR, DBT blocks as needed and modify as needed.

**Example of directional bore details for Engineering/Construction Prints**

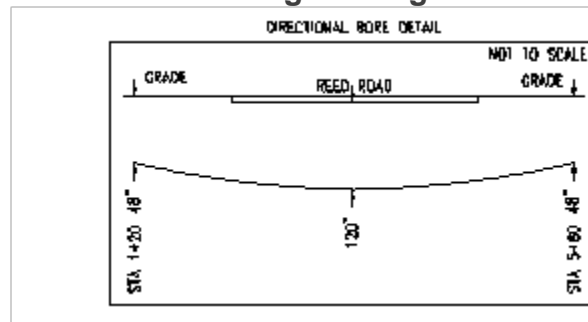

### 29.1 Drawing instructions for Directional Bore Details for Final As-Builts

(Should use DB Program when possible)

See “Creating Directional Bore Detail” section of the AutoCAD Setup Manual

1. Detail should be drawn not to scale, but **proportionally**.
2. Draw stations and depths of detail to scale, then scale up the detail 1 ½ to 2 times for clarity on as-built drawings.
3. Dimensions on depths are to be shown in inches.
4. Text height should be 6.25, width .75.

5. Tracks and Roads
  - a. The track is to be drawn with 2 lines, magenta and 2' apart (before scaling)
  - b. A road is to be drawn with 1 line and yellow
  - c. To represent a road crossing the baseline road use 1 line, yellow, 3' away from road (before scaling)
  - d. To represent a road crossing the baseline track use 1 line, yellow, 2' away from track (before scaling)
6. The cable and the grade should be fit curved by the pedit command and the cable should be drawn as a curve.
7. Label the name of the track. Example: Southern Pacific R/R
8. Hatching pattern is earth with a 30 scale and a 45-degree angle.
9. Hatching should be drawn halfway between the cable and the grade.
10. If boring under a bridge, draw bridge as simplified as possible.
11. If boring under a road, use a yellow pline with a width of 1.1 to represent the road and it is to be placed 2' above the top line of the track.
12. If no grade variation shown, then dimension from the top line of the track.
13. If the directional bore covers 2 or more as-built drawings, then show detail on all drawings. If the directional bore detail does not fit on the first drawing where the DB starts, then add the DB detail to the drawing where the DB ends. Use reference notes to indicate what drawing the DB is on.
14. To represent a match line, use "sheet" block and label each side of the line which drawing it represents; also, station the match line.
15. To represent a mile post, use "MP" block.
16. See drawing procedures and bore examples.

## 29.2 Examples of directional bore details for As-Built

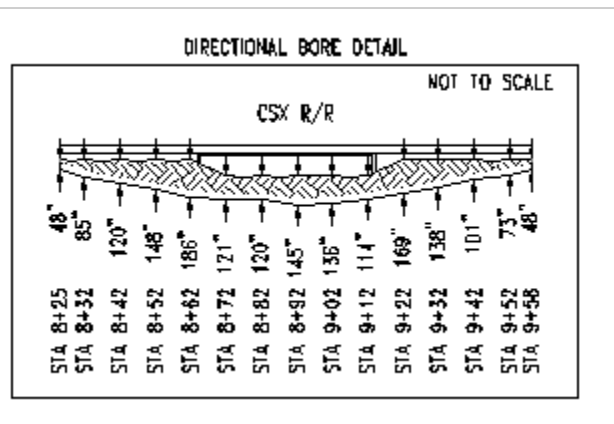

Show the track block every time the directional bore crosses a track.

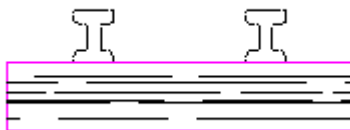

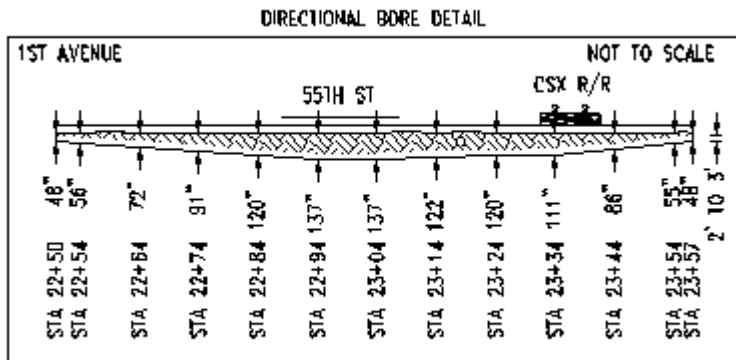

**Additional Directional Bore information on an as-built**

Example of Directional Bore without Steel: Use IDB Lisp to insert the DB in the line



Example of Directional Bore with Steel: Use IDB Lisp to insert the DB in the line

**Note:** The letters “DB” do not need to be placed in the directional bore detail.

1. Directional Bore (DB) without steel should be drawn with a pline width of 3'(for 100 scale).
2. DB with steel should be drawn with a pline width of 6'(for 100 scale).
3. All DB lines will be on layer cable.
4. A Directional Bore statement showing footage (including ADF if applicable) will be placed above each directional bore.

Example:                    DIRECTIONAL BORE^^250'

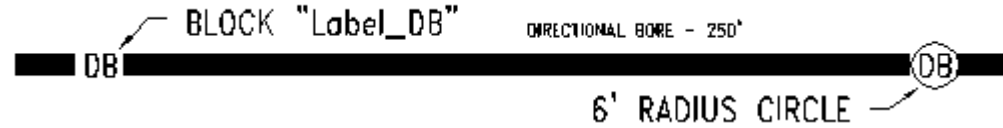

The “DB” symbol needs to be placed approximately 15 feet from the beginning and 15 feet from the end of the Directional Bore. You can use LISP IDB to add the DB text to your Line

Be sure to move the dimension approximately 3’ away from the bore to clear the 3’ or 6’ wide pline.

If the Directional Bore spans more than one sheet, place the “DB” approximately 50’ from the matchline of both the end of the first sheet and the beginning of the second sheet.

If the “DB” will not fit at the above locations it may be put anywhere on the directional bore it will fit. If it will not fit anywhere then do not place a “DB” and leader the Directional Bore stating Directional Bore.

If by chance the end of one directional bore is the same station as the beginning of another you need to call it out as such.

Insert "Sheet" for sheet change (Add "MP" to top if mile changes)

Insert tracks and roads accordingly

## 30 PVC Placement

Drawing instructions for Bore with PVC Placement

Can also use PVC LISP

1. Draw pline from beginning to end of bore.

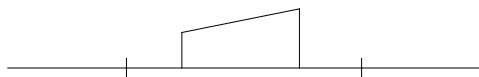

6. Dimension at the beginning and end of bore.

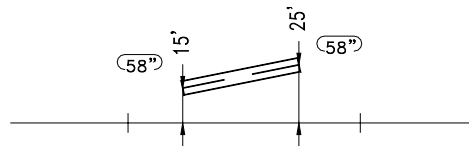

2. O/S pline 3' to the top and bottom of pline.



7. Calculate if any added footage has occurred

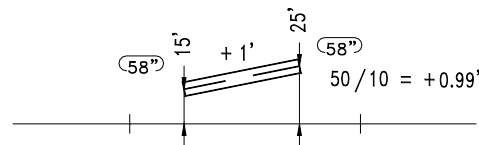

3. Draw pline from endpoint to endpoint of of bore.

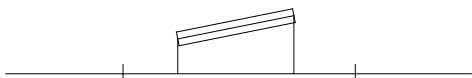

8. Insert station callouts and arrows for each side Bore. Label callouts "BEGIN PVC BORE" and "END PVC BORE". If R/L change has occurred then add "& R/L CHANGE" to callout.

## 31 Buried Service Pipe (BSP)

Drawing instructions for Jack and Bore with Steel Placement  
("Place Object" will also draw this but not insert the covers)



1. Draw pline from beginning to end of bore.
2. Calculate bore if any added footage has occurred.

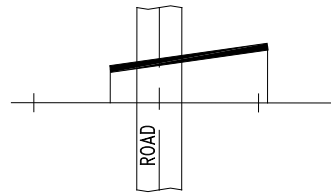
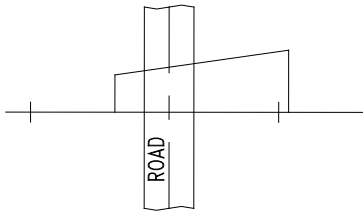

3. Change width of pline to 6.

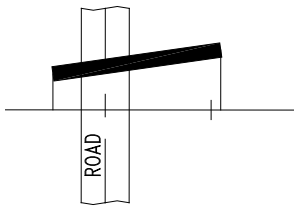

4. Dimension at the beginning and end of bore.

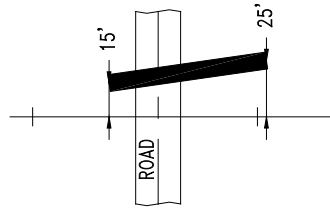

5. Calculate bore if any added footage has occurred.

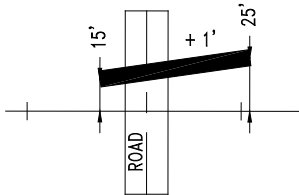

6. Insert "cover block for each end of bore.

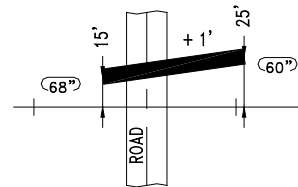

6. Insert station callouts and arrows for each side of the bore. Label callouts "Begin 6" BSP Bore" and "End 6 BSP". If R/L change has occurred, then add "& R/L Change" to callouts.

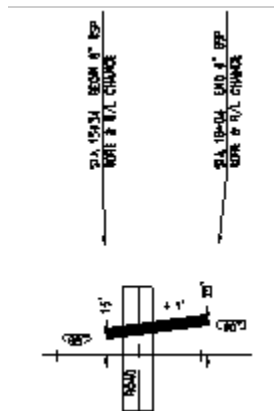

### 31.1 BSP Placement

#### Trench & Place BSP – Not Bored

(“Place Object” will also draw this)

1. Draw pline from beginning to end of BSP.
2. O/S pline 3’ to the top and bottom of pline.

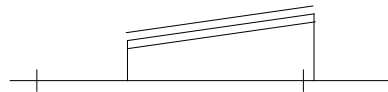
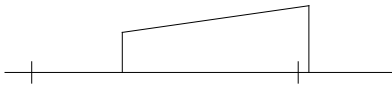

3. Draw pline from endpoint to endpoint of and

each O/S line.

4. Change those lines to the cable layer

magenta color.

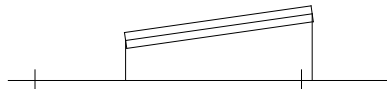
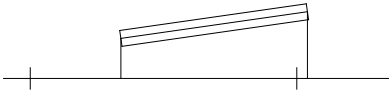

5. Change middle line to cable layer.

6. Insert “zigzag” block and insert it at the beginning of BSP.

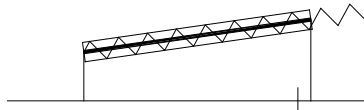

7. Trim or add another “zigzag” block

8. Dimension at the beginning and end of BSP.

accordingly.

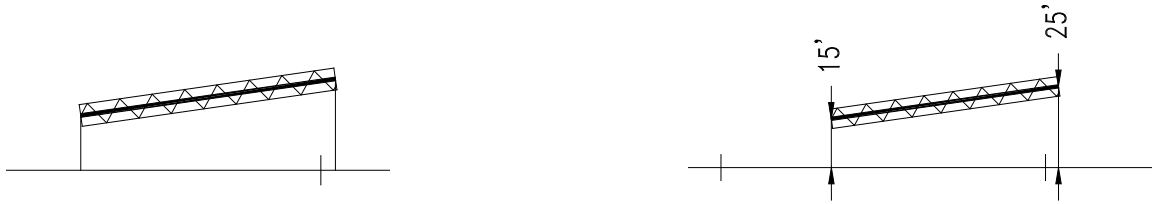

9. Calculate BSP if any added footage has occurred.

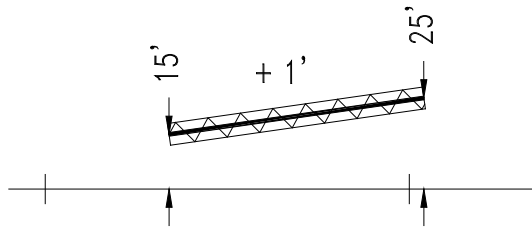

10. Insert station callouts and arrows for each side of BSP. If R/L Change has occurred, then add “&

R/L Change” to callouts. Do not place an End BSP callout if you are beginning a BSP Bore at the same station.

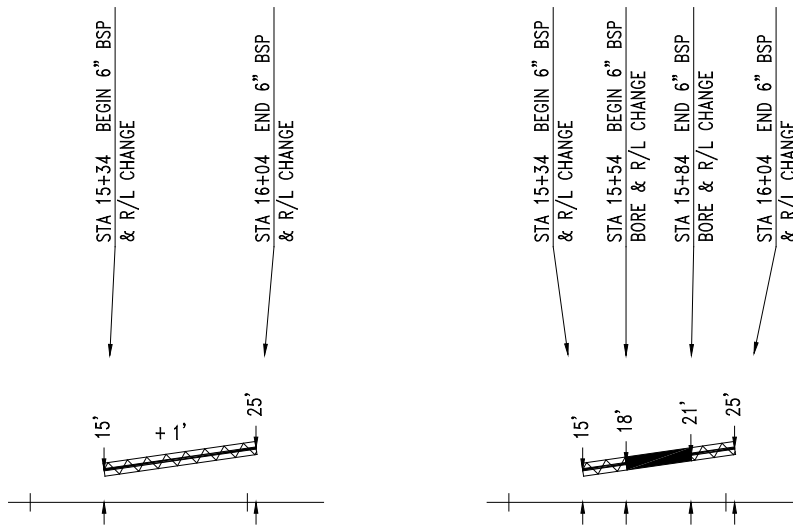

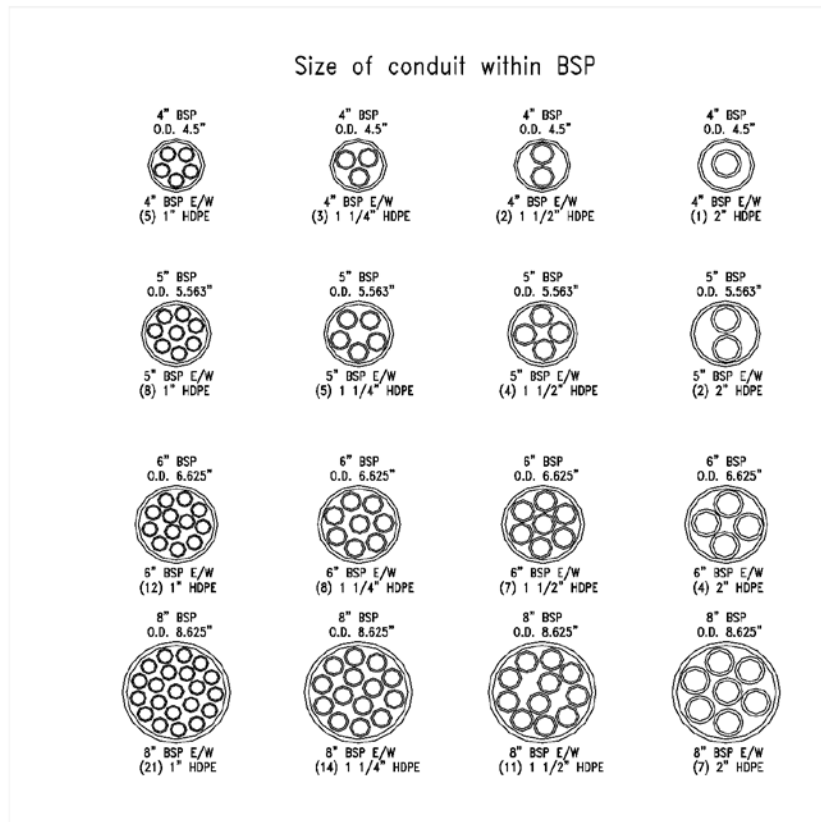

## 32 HDPE Bore

Use "Place Object" program for BSP Bores and then erase the ZIGZAG

1. Draw pline from beginning to end of bore. has occurred.

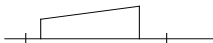

2. O/S pline 3' to the top and bottom of pline.



3. Draw pline from endpoint to endpoint of each O/S line.

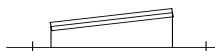

4. Change those lines to the cable layer.



5. Erase middle line.

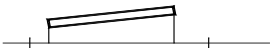

6. Insert "cover" block for each end of bore.



7. Dimension at the beginning and end of bore.

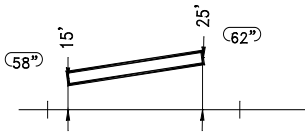

8. Insert station callouts and arrows for each side of the bore.

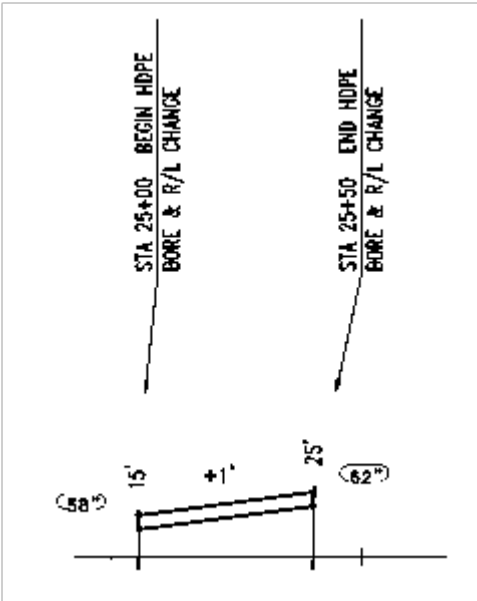

### 33 HDPE Configurations

Use the HDPE Config Creator from the Drafting Tools section of the OSP-CAD menu - Unless you have Configurations that are One inside of the other. There are blacks made for the most typical. If you don't have what you need – Contact OSP Design at AskOSPDesign@CenturyLink.com

Make sure you put the correct size, color and owner below are just examples.

1. Insert correct HDPE configuration if it is not already in drawing.

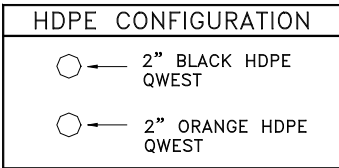

#### If Config Changes on same sheet

2. Burst entire block once. Explode rectangle. Erase top line and the text "HDPE CONFIGURATION"

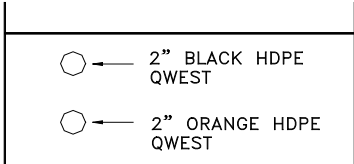

3. Insert "HCSTA" on the midpoint of the top line of the HDPE configuration.

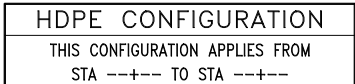

4. Change STA# to STA# as needed with the DDEDIT Command.

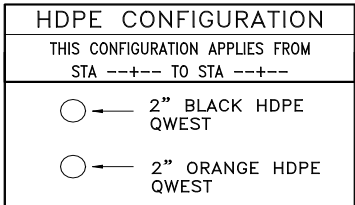

## 34 Handholes

### Drawing instructions for Handhole Placement:

#### See Block Section for what blocks to use

#### Use the place object program when adding

1. Insert appropriate block “HH” or “HHH” at the correct station number and all others are 10 feet from the insertion point of one handhole to the insertion point of the next handhole.
2. The leader of the handhole callout needs to point to the intersection of the left wall of the handhole and the running line.
3. Stationing for handhole placement will be at the left wall of the handhole. Stationing for conduit or cable, will resume at the right wall of the handhole (usually 5’).
4. For more than one conduit system:  
If handhole is 5’ or more away from the running line show the other HDPE going around the handhole. If the handhole is 4’ or less away from the running line do not show the HDPE going around because it will overlap “HH” block.
5. A dimension should only be placed if it is a running line change
6. To callout a handhole, it must be stated as EXISTING “Company Name” HANDHOLE for an existing handhole. For a new handhole being placed it is stated as PLACE “Company Name” HANDHOLE.

#### Example:

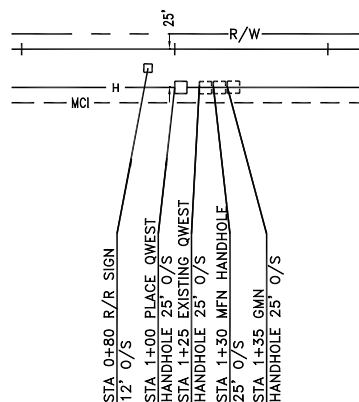

## 35 Manholes

Manholes are placed instead of handholes usually when running line is within a paved road.

- Manhole Butterfly Details
- Using Leaders
- Block Name: MH-BUTTERFLY
- Conduit Circle Block Name: MH-CIR
- Conduit Leaders and Text Block Name: MH-TEXT
- Cable Dot Block Name: CABLE

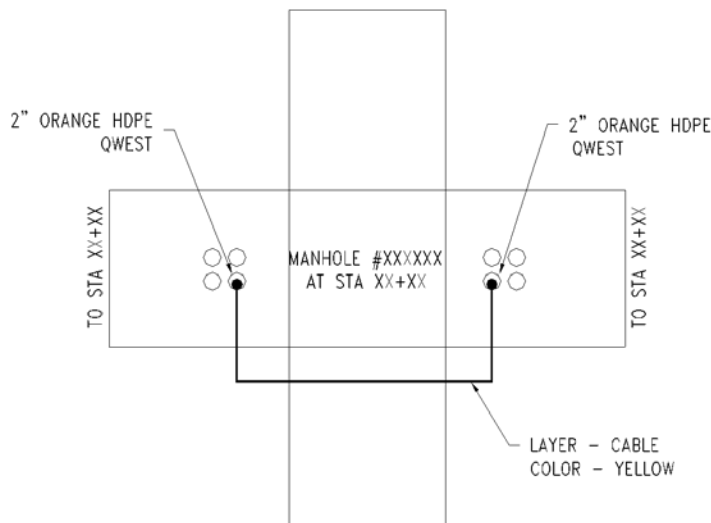

- Identify each carrier that is known.
- Size & color of HDPE
- Draw location of where cable enters and leaves the manhole
- Add manhole number if available

### 35.1 Using Tables

Manhole Butterfly Detail Block Name: MH-BUTTERFLY  
 Conduit Circle Block Name With Number: MHC# (See Note)  
 Tabular Description Table: MH-DETAIL# (See Note)

**Note:** The “#” sign after the block “MHC” indicates the number of ducts entering and leaving the manhole. The “#” sign after the block “MH-DETAIL” indicates the number of duct positions shown in the table. (In the example below, the manhole butterfly detail shows (8) ducts entering and leaving the manhole using block “MHC8”. The (8) duct positions shown in the tables are using block “MH-DETAIL8”).



| NO | SIZE   | COLOR  | OWNER           |
|----|--------|--------|-----------------|
| 1  | 1 1/4" | ORANGE | QWEST/Q1 #XXXXX |
| 2  | 1 1/4" | BLACK  | QWEST/QVAC      |
| 3  | 1 1/4" | BLUE   | QWEST/QVAC      |
| 4  | 1 1/4" | YELLOW | QWEST/QVAC      |
| 5  | 1 1/4" | ORANGE | QWEST/QVAC      |
| 6  | 1 1/4" | BLACK  | QWEST/QVAC      |
| 7  | 1 1/4" | BLUE   | QWEST/QVAC      |
| 8  | 1 1/4" | YELLOW | QWEST/QVAC      |

| NO | SIZE   | COLOR  | OWNER           |
|----|--------|--------|-----------------|
| 1  | 1 1/4" | ORANGE | QWEST/Q1 #XXXXX |
| 2  | 1 1/4" | BLACK  | QWEST/QVAC      |
| 3  | 1 1/4" | BLUE   | QWEST/QVAC      |
| 4  | 1 1/4" | YELLOW | QWEST/QVAC      |
| 5  | 1 1/4" | ORANGE | QWEST/QVAC      |
| 6  | 1 1/4" | BLACK  | QWEST/QVAC      |
| 7  | 1 1/4" | BLUE   | QWEST/QVAC      |
| 8  | 1 1/4" | YELLOW | QWEST/QVAC      |

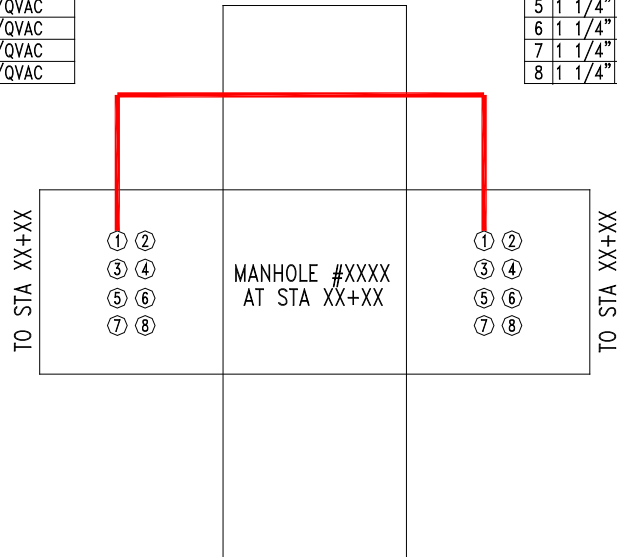

- Identify each carrier that is known.
- Size & color of HDPE
- Draw location of where cable enters and leaves the manhole
- Add manhole number if available

## 36 Aerial Build

Add station callouts for poles with pole number and offset if available (example below)

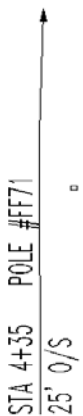

Fiber optic Cable line will be drafted using on the "Cable" layer from the Tangent of the pole blocks. The PP block is used to show the footages between the poles.

# 37 Buildings

Indicate beginning and ending station number with offset.

- Layer: Objects
- Hatch Pattern: Ansi31
- Hatch Scale: 30
- (Force hatch color to white)
- Use Regen blocks to add address and CLLI

Example:

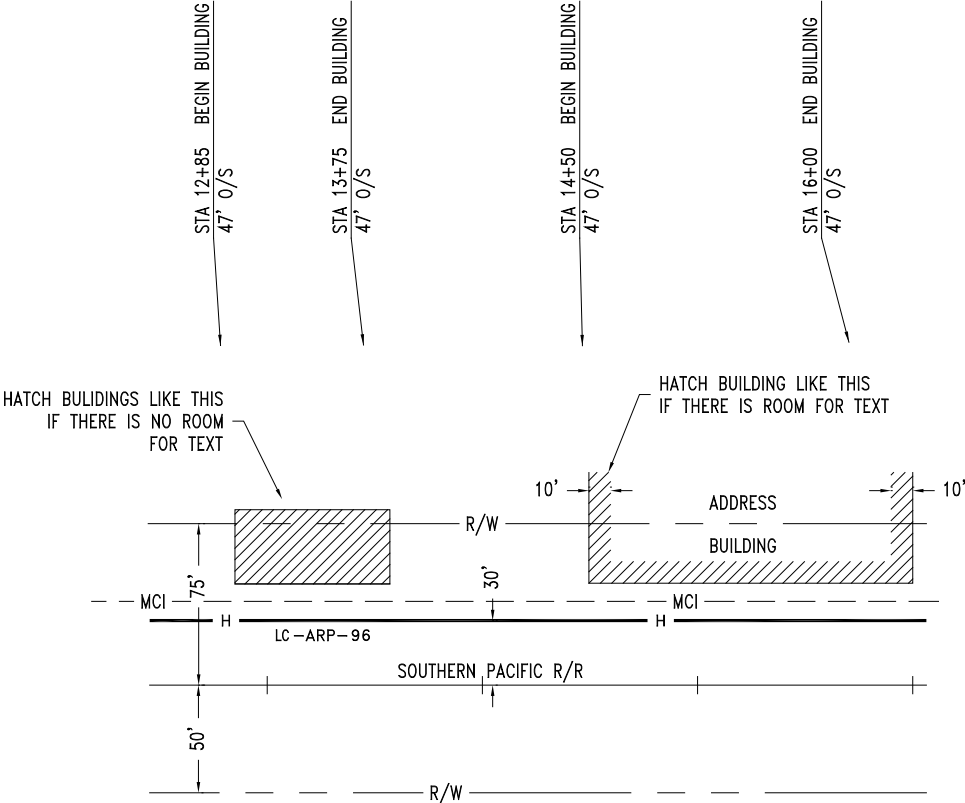

## 38 Building Access Agreement Drawing Requirements

Drawings are required to negotiate a BAA for new construction or augment an existing facility. Several key components are critical for success negotiations, the following list it what needs to be included in the BAA drawing packet

- Use existing Title Block (Base) for all drawings
  - Site Drawing
    - Use satellite image, a picture could be worth a thousand words to the property manager.
    - Running line added to image to represent the build to the building (Use cable linetype and cable layer) Just provide routing for the customers property, not the entire build back to the Fiber network
    - Be sure to add a simple scope of work pertaining to conduit placement, pull box placement, or use of existing conduits. Add as a note in the drawing
  - Elevation Drawing
    - Riser drawings – all information in the riser drawing should be put on the objects layer
    - Example:

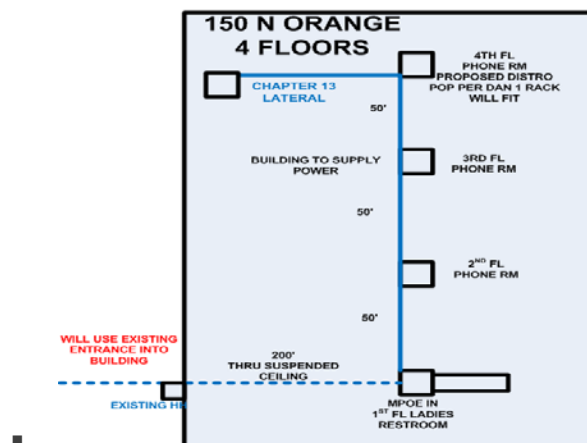

- 
- Floor Plan Drawing (Min requirements) – Put everything on the object layer
    - Outline of building
    - Routing of the fiber on the correct floor
    - Rack showing FDP and where it is on the floor plan
      - There is dropdown under building on the menu to place the FDP

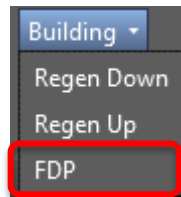

- Pictures
  - Pictures inserted in to Base
  - Add comments, arrows, etc. to define the picture or how it relates to the work to be done.
  - Individual conditions will dictate the number of pictures needed to depict key points like entrance conduits, pathways and equipment space.
  - Minimum to include is the following:
    - Entrance into building
    - Rack where equipment will be placed
    - Conduit that fiber will placed in inside the building

## 39 Blocks

All blocks shown in examples are not to scale. See full color detail for drawing description. [Where?](#)

- **DO NOT** use any other symbols without management's approval.
- **DO NOT** change any symbols or names without management's approval.
- **DO NOT** explode any symbols unless otherwise noted.

### 39.1 ARP

Block Name: ARP  
Layer: CABLE

This block is used to show cable manufacture-armour protected-fiber count  
See Cable Section for more information on when, how and where to use this block

LC-ARP-48

### 39.2 Arrow Head

Block Name: ADH  
Layer: Match the layer and color of the line it is attached to  
LISP: Terminate

This block is used to add an arrow to the end of a line



### 39.3 Boxpole

Block Name: POLE (Pole block with box shown)  
Layer: CABLE  
See POLE block for Details



### 39.4 Bridge

Block Name: BRIDGE  
Layer: CULVERTS

This block is used to show a bridge along or crossing your baseline. (Block is dynamic so can be stretched as needed)

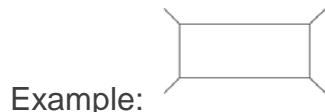

### 39.5 Cable

Block Name: CABLE

Layer: Details

This block is used to show cable placement in the HDPE configuration blocks & manhole butterfly details. Example:



### 39.6 Caution

Block Name: CAUTION

Layer: Notes

Used on engineering drawings or on As-Builts when directed.

Example: (One dynamic block used for either direction)



### 39.7 Chevron

Block Name: CHEV

Layer: Correct cable layer

This block is used to show cable information at splice points.

See Cable Section for more information on when, how and where to use this block

Example:

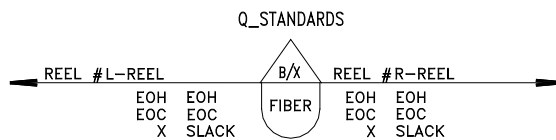

There are many different CHEV blocks available. A complete list is in the Cable section of this book.

### 39.8 City Limits

Block Name: CITYLIM

Layer: Text

This block is used to show when a city limit begins and/or ends.

Example:



---

### 39.9 County

Block Name: COUNTY

Layer: Border

This block is used to show the County and City in top section of the base.

Example:

COUNTY  
CITY

---

### 39.10 Bore Cover

Block Name: COVER

Layer: Cable

This block is inserted at the end of all conventional road, track and HDPE bores to show the depth at each end.

Example:

48”

### 39.11 Culvert

Block Name: CULVERT

Layer: Culverts

This block is used to identify culverts and is to be placed on the baseline at the proper stationing & offsets (O/S). (Block is dynamic so can be stretched as needed)

Example:

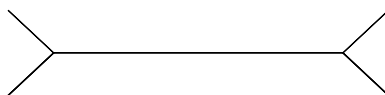

### 39.12 Directional Bore Detail

Block Name: DBD

Layer: Text

This block is used to identify a Directional Bore Detail

Example: See Directional Bore Section of this book

### 39.13 Text

Block Name: DBTEXT

Layer: Text

This block is used to add Directional Bore Footage Note

Example: See Directional Bore Section of this book

### 39.14 Railroad Equations

Block Name: EQL / EQR

Layer: Text

This block is used to identify railroad equations.

Extend the line portion of this block to the baseline as needed in order to keep the text from interfering with any of the lines such as the R/W line.

Example:

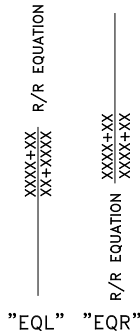

### 39.15 Fire Hydrants

Block Name: FH

Layer: Objects

This is used for fire hydrants.

Example:

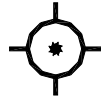

### 39.16 Guardrails

Block Name: GRD-DWN / GRD-UP

Layer: Road Lisp: Guard

This block is used to represent guardrails on the road.

Example of block:

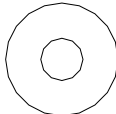

Use LISP routines to place block on line every 50'

- Use GRDB for bottom of line
- Use GRDT for top of line

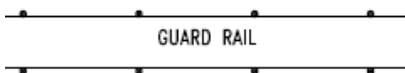

Example of what lines look like:



### 39.17 Fiber Markers

Block Name: HU / HD (Hidden Up and Hidden Down)

Layer: Markers

This block is used to identify previously placed markers by other **Fiber Optic Carriers**. (Use appropriate block for correct side of baseline.)

Example:

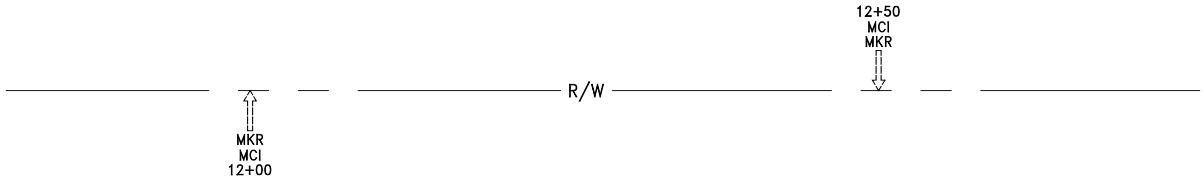

Block Name: TU / TD

Layer: Marker

This block is used to identify markers placed on projects for CenturyLink Communications Corporation, LLC.

TU: Tubular marker that points up and is placed on the bottom side of the baseline.

TD: Tubular marker that points down and is placed on the topside of the baseline.

Tip of marker should intersect edge of row and station.

**Note:** The station number is always to the outside on both blocks. Place & rotate perpendicular to baseline.

Example:

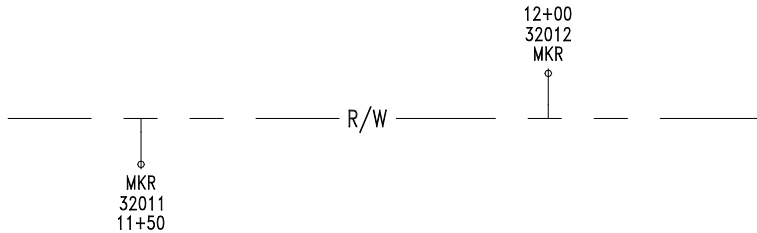

### 39.18 CenturyLink Owned Handhole

Block Name: HH

Layer: Cable

This block is used to identify handhole placement for the carrier on the project.

Example:

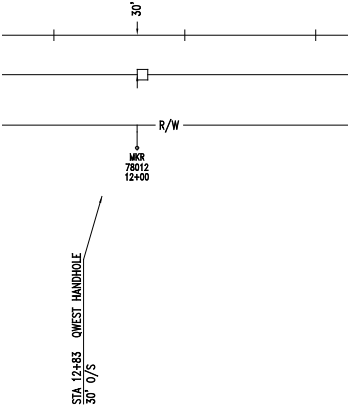

### 39.19 Other Handholes

Block Name: HHH

Layer: Cable

This block is used to identify handhole placement for **other** carriers

**Note:** A hidden handhole is called out just like a solid handhole.

Example:

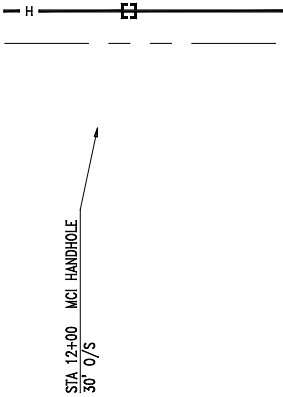

### 39.20 Matchline

Block Name: M1 (Left Side of drawings) (just the text not the line)

Layer: Match

This block is used at the beginning of all As-Built drawings to identify match line information. i.e. drawings to see, railroad stationing & survey stationing.

Example:

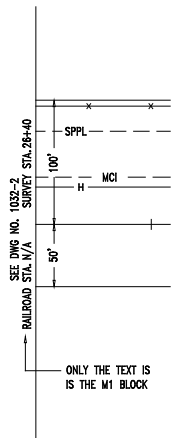

Block Name: M2 (Right side of drawing) (Just the text not the line)

Layer: Match

This block is used at the end of all As-Built drawings to identify Match Line information. i.e. drawing to see, railroad stationing & survey stationing.

Example:

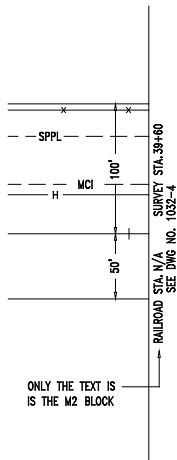

Block Name: ML

Layer: Match

This block is used to identify match lines at the beginning and ending of each As-Built.

**Note:** Make sure continuity from As-Built to As-Built is consistent. Must be perpendicular to baseline.

**Note:** The length of the match line should be 350' and perpendicular to the baseline.

Example:

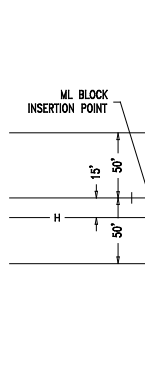

### 39.21 Manhole

Block Name: MH

Layer: Cable

This block is used to identify all types of manholes.

Example:



### 39.22 Milepost

Block Name: MP

Layer: Match

This block is used to show the actual milepost in the field. It is placed at the end of the match line.

Example:



Block Name: MPNIF (Milepost Not in the Field)

Layer: Match

This block is used to identify milepost not found in field. It is placed at the end of the match line.

Example:

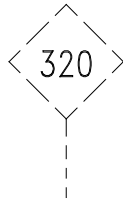

### 39.23 North Arrow

Block Name: NAROW

Layer: Title

This block is used to identify the North arrow on the Base Drawing. Note: The orientation of the North Arrow is pulled from Val-Maps.

**Note:** Proper rotation of the North Arrow should be shown on all drawings.

Example:

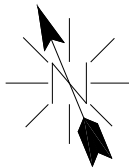

### 39.24 Railroad Objects

Block Name: OBJECT

Layer: Objects

This block is used to identify Railroad objects. i.e. R/R Signal box, R/R Grease box, Gas Markers, Etc.

Example:



### 39.25 Pole

Block Name: Pole (Pole block with Anchor shown)

Layer: Objects

**Note:** Rotate anchor accordingly.

Example:

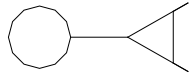

Block Name: POLE (Same block used for Pole with anchor and Boxpole)

Layer: Objects

This block represents all poles i.e. power and utility poles.

**Note:** If the type of pole is identifiable indicate so: i.e. power pole

Example:

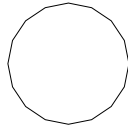

### 39.26 Parallel Objects

Block Name: PARCALL

Layer: Text

This block is used to identify objects parallel to the running line (i.e. trees, brush, roads).

Example:



### 39.27 Pedestal

Block Name: PEDESTAL

Layer: Objects

This block is used to identify a telephone pedestal.

Example:



### 39.28 Point of Intersection

Block Name: POI  
 Layer: Text

This block is used to identify the point of intersection where two baselines intersect. (See Section E for additional information on point of intersections)

Note: Drawing a line from the intersection to the outside circle of the POI when using Example:

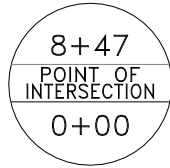

### 39.29 Point of Switch

Block Name: PS (Point of Switch)  
 Layer: Track

This block is used to show a point of switch and derail switch on the tracks.

**Note:** Do not call out the offset.

Example:



### 39.30 Regen Sites

Block Name: REGEN-D / REGEN-U  
 Layer: Notes

This block is used to identify regen sites.

Add address and or CLLI code where the text “REGEN-U” and “REGEN-D” is located below  
 Used for all sites not just Regens

Example:

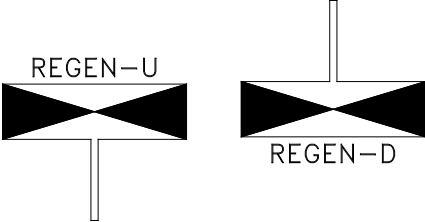

### 39.31 Retaining Wall

Block Name: RETAIN (10, 20, 30, 40, and 50)

Layer: Retwall

This block is used to identify retaining walls from the beginning to the end.

**Note:** If a retaining wall differs from 10' increments, burst RETAIN 10 and modify as needed.

Example:



### 39.32 Baseline

Block Name: RTIC

Layer: Baseline

This block is used as a baseline identifier. Spacing on baseline is 100' apart. Every fifth tic should be labeled with a station number.

**Note:** Be sure the rtic is on the top of the baseline.

Example:

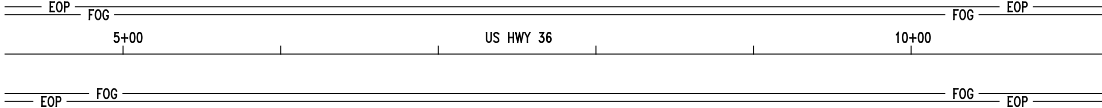

### 39.33 Right of Way

Block Name: RW

Layer: Notes

This block is used to note that the Right of Way exceeds 200'.

**Note:** If you are able to show a 200' R/W on the drawing then do so, if space allows it.

Example:



NOTE: R/W EXCEEDS 200'  
THIS AREA

### 39.34 Leader

Block Name: STA\_LDR

Layer: Text

This block is used as a pointing symbol. Points to the insertion point of blocks and intersection of baseline & crossing object etc. (Refers to the leader line)

Example:



### 39.35 Stations

Block Name: STATXT\_B / STATXT\_T

Layer: Text

These blocks are used as object identifiers. i.e. stations of the object & callout of the objects. **Note:** STA\_LDR points to the object that it is identifying.

**Hint:** Use STA or SBA to insert individual callouts. (see L section of this book)

Example:

STA 25+00 R/L CHANGE

### 39.36 Trees

Block Name: TREE

Layer: Objects

This block is used to show all trees.

Example:



### 39.37 Railroad Track

Block Name: TIC

Layer: Track

This block is used as a track identifier, i.e. main line vs. siding or spur. Spacing on main line tracks are 100' apart. All other tracks are 50' apart. (Siding & Spurs)

**Note:** Be sure the tic is centered on the track line.

Example:

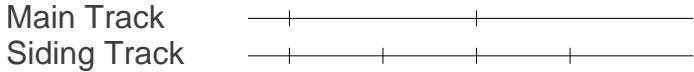

### 39.38 Slopes

Block Name: TOE / TOE-UP

Layer: Slope Lisp: Slope

This block is placed at the bottom of the slope every 50'

**Note:** TOE-UP represents the opposite side of the line of TOE.

Example:

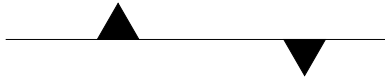

Block Name: TOP / TOP-DWN

Layer: Slope Lisp: Slope

This block is placed at the top of the slope every 50'

**Note:** TOP-DWN represents the opposite side of the line of TOP.

Example:



Another example of slopes: (Dimensions not shown on drawing- added for reference

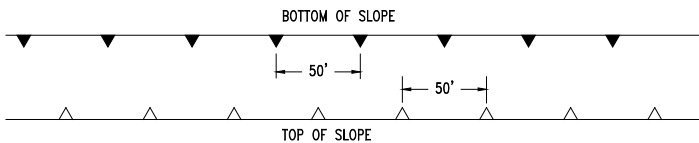

here)

### 39.39 Utility Lines Overhead/Underground

Block Name: UTIL\_OH / UTIL\_UG

Layer: Utility

These blocks are used to identify perpendicular utilities overhead and underground.

**Note:** A hidden line represents underground utility and the continuous line represents an aerial utility. Should extend 25' past R/W on each side.

Example:

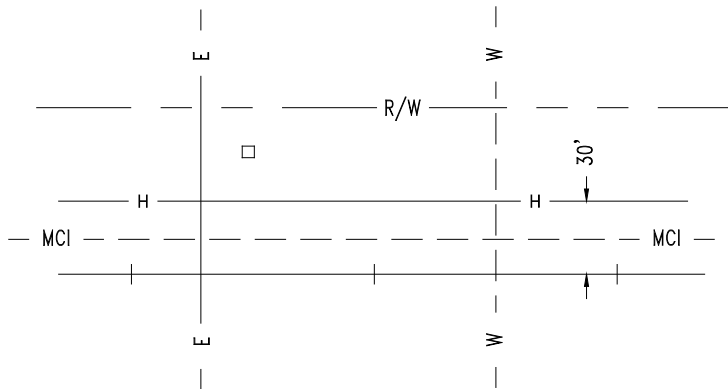

### 39.40 Valve

Block Name: VALVE

Layer: Objects

This block is used to identify a valve, i.e. water valve, gas valve, etc.

Example:

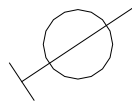

### 39.41 Reference Point

Block Name: VEE

Layer: Guidelines

This block is used for reference point only.

Example:



### 39.42 Vents

Block Name: VENT

Layer: Objects

This block is used to show vents, i.e. gas vent, air vent, etc.

Example:



### 39.43 Val-Map Milepost

Block Name: VMP

Layer: Notes

This block is used to identify the Val-Map mileposts according to Val-Maps, not field notes.

Example:

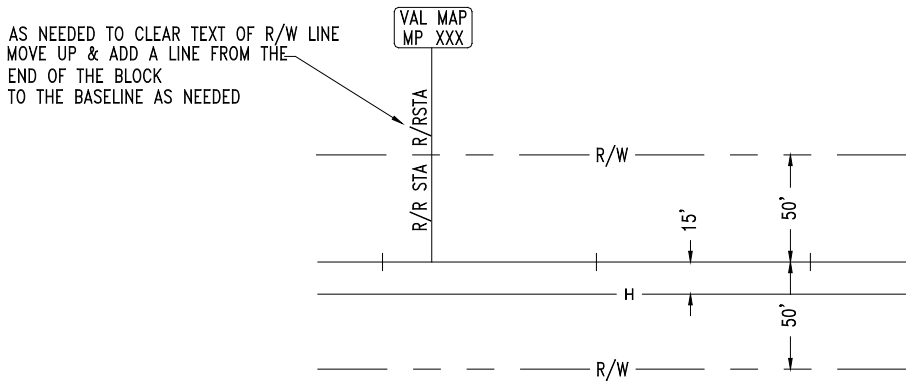

## 40 Parcall Block

The “Parcall” block is used to represent the following parallel features from sheet to sheet in order keep drawings from getting cluttered.

- Roads
- Trees
- Ditches
- Rock Areas
- Brush
- Rivers
- Swamps

Example:

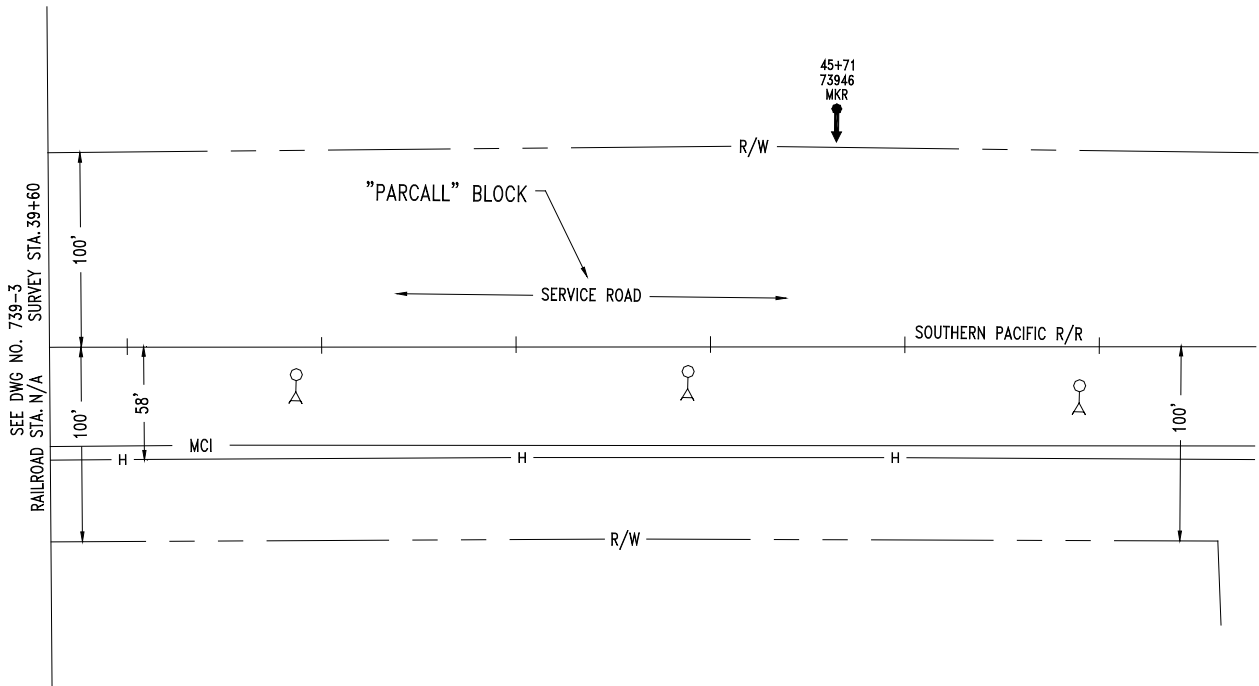

## 41 Objects

The object blocks are not to scale. If the running line is affected by an object move the object slightly out of the way. When you have two objects with the same station number you can combine the text on your callout only if the leader line will cross over both objects.

Take all caution signs out except Cathodic Protection Systems

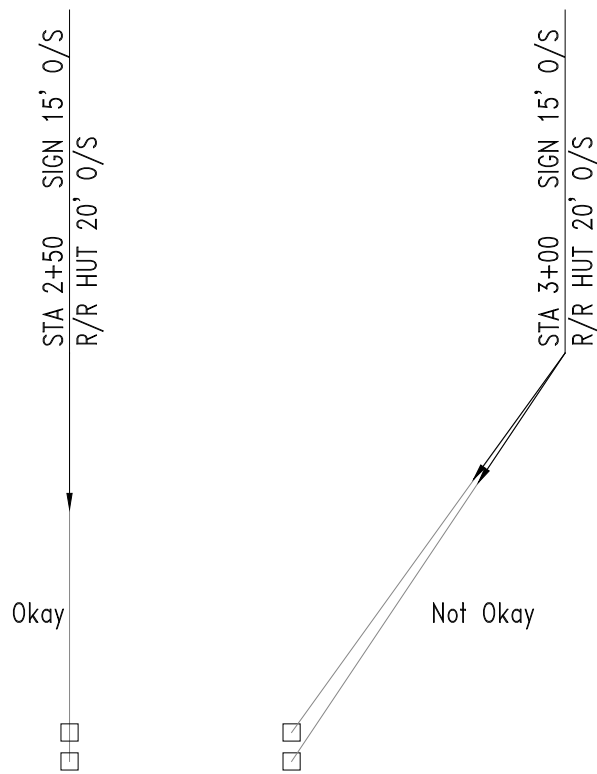

## 42 Plotting

All these settings are in the Qwest.CTB

### HP Laser Jet printer using 11" x 17" paper

In the AutoCAD plot configuration change the settings to:

Color 1 = pen 1 width in configuration = .005

Color 2 = pen 2 width in configuration .018

Color 3 thru 6 = pen 1 width in configuration = .008

Color 7 thru 255 = pen 1 width in configuration = .005

Origin = .67, .30, 0 degree rotation

Paper = regular 11" x 17"

Scale appropriately

### HP plotter using 11" x 50-yard roll feed.

In the AutoCAD plot configuration change the settings to:

Color 1 = pen 1 width on the plotter = .018

Color 2 = pen 7 width on the plotter = .050

Color 3 thru 6 = pen 4 width on the plotter = .025

Color 7 & 8 = pen 1 width on the plotter = .018

Color 9 = pen 9 width on the plotter = .013

Color 10 = pen 4 width on the plotter = .025

Color 11 = pen 1 width on the plotter = .018

Color 12 thru 255 = pen 4 width on the plotter = .025

Origin = .2, .4, 0 degree rotation

Paper size is set at 15.68, 10.6

Scale 1=100

## 42.1 Plot Settings (Model Space)

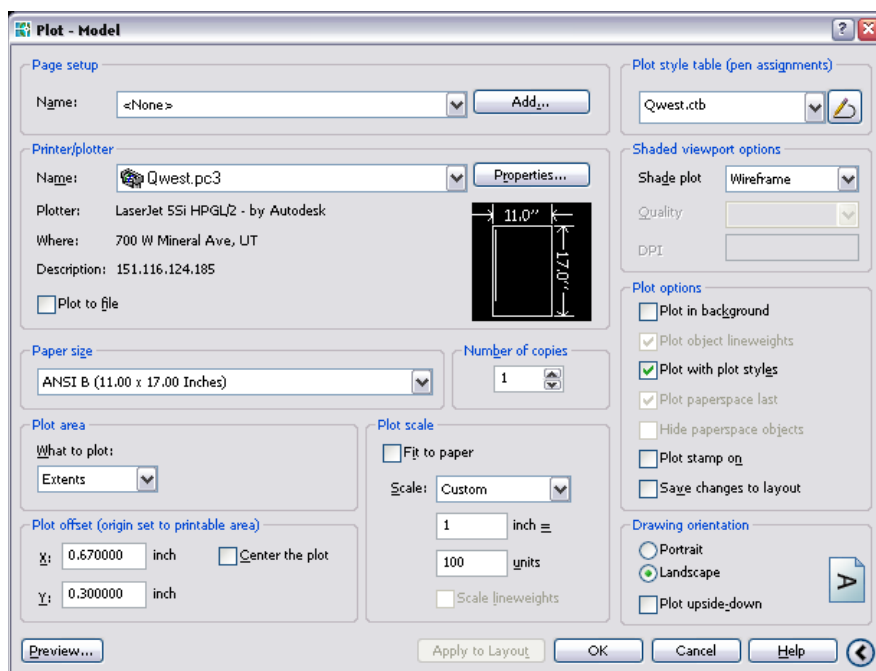

## 42.2 Plot Settings (Paper Space)

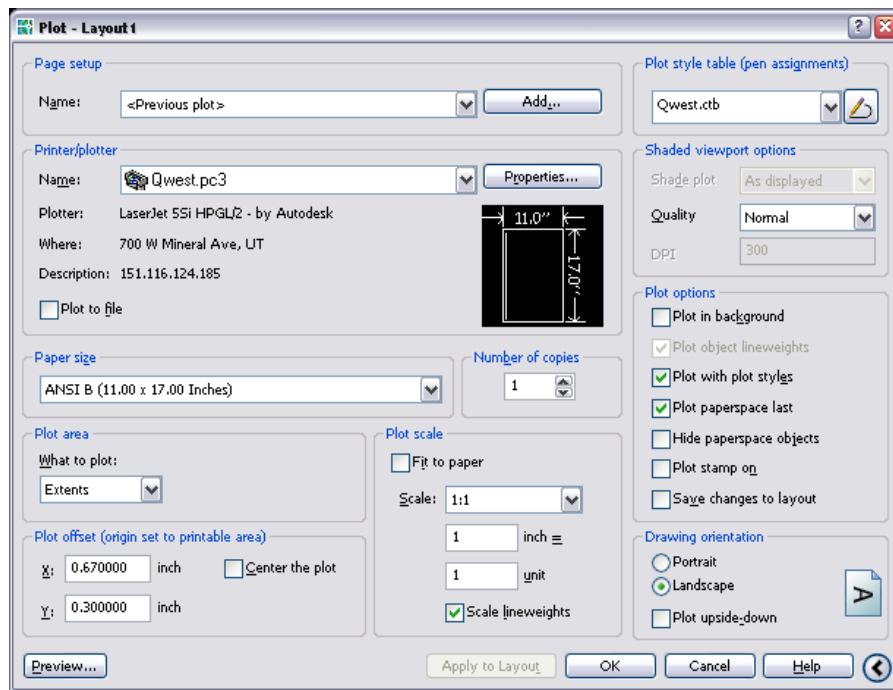

## 43 QA Quality Assurance Checklist

Use this list to Check that drawings were made to standards

### 1. Check all typical title block information

#### Block Description

- To & From designations
- County, City & State designations
- R1 block & R2 block consistency
- North arrow
- Project number
- Segment/span, ring number or activity designation
- To & From designation
- Section, Township, Range (if available)
- Logo & overall To & From designation
- Proprietary note
- Build block and/or Rev-Build block
- Scale block
- Mile Post to Mile Post
- Drawing number

### 2. Check all typical drawing information

- ARP
- R/W Designation



- 
- Track names and/or street names
  - Siding & Spur designation
  - Correct Linetypes are used
  - HDPE Configuration
  - Surge box & ground block at every handhole splice point (except EWD's)
  - Mile post at beginning & end of mile
  - PVC, BSP, Directional Bore, Concrete Encased & Cut & Restore line types (Note: DB designations & Directional Bore Footage note added to Directional Bores & Cover( Depths) added to BSP & PVC bores)
3. Check & Verify match line M1 & M2 information
  4. Check for right of way (R/W) dimensions at beginning and end of sheet, also at every R/W change (Note: check that HDPE is within the R/W line)
  5. Verify station callouts are 100' off of R/W
  6. Verify spacing & continuity of track tic marks for track builds & rtic & stationing for road builds
  7. Station by station comparison from redline to drawing if redlines are available
  8. Check to ensure markers & station callouts are on correct side of baseline
  9. Check station order
  10. Check for running line (R/L) offset dimension at every change, also at beginning and end of sheet (if last change is 150' or more away from match line place a dimension close to the match line)
  11. Marker by marker comparison to markers sheet and/or redlines
  12. Check to ensure all handholes have a configuration & a marker
  13. Fold sheets at match line (ML) to check sheet continuity
  14. Check detail drawings (directional bore details, manhole butterfly details, etc..)
  15. Check cable information from cable sheets
    - R1 Block & R2 block (R2 when applicable)
    - Sequential block is present at handholes & correct per cable sheets
    - Chev block is present at splice points & correct per cable sheets (**Note:** ARP is shown on both sides of a splice point; surge box & ground block shown on handholes only)
    - ARP block is correct per cable sheets
    - "CABLE" block is shown in correct size & color in HDPE configuration
  16. Check revision block in title block is filled out and detail note is on drawings when applicable
-

## 44 Revisions

Use Note Program to add revision note to existing drawings  
 Make sure Revision section of Title block is filled in

## 45 Help

For any questions, missing data, program issues and or not sure what to do contact  
[AskOSPDesign@CenturyLink.com](mailto:AskOSPDesign@CenturyLink.com)

## 46 Abbreviations

Standards Abbreviation Master List

|                           |        |
|---------------------------|--------|
| ACCOUNTED                 | ACCT   |
| ADDED FOOTAGE             | ADF    |
| ADDITIONAL                | ADDTNL |
| AND                       | &      |
| ARMORED RODENT PROTECTED  | ARP    |
| ARROW                     | ARR    |
| AS-BUILT                  | ASBT   |
| AT                        | @      |
| AVENUE                    | AVE    |
| BACKBONE                  | BB     |
| BLACK                     | BLK    |
| BLACK STEEL PIPE          | BSP    |
| BLUE                      | BLU    |
| BOULEVARD                 | BLVD   |
| BRIDGE                    | BRDG   |
| BROWN                     | BRN    |
| BUILDING                  | BLDG   |
| CABLE                     | CA     |
| CABLE TV                  | CATV   |
| CENTERLINE                | C/L    |
| CENTRAL BUSINESS DISTRICT | CBD    |
| CENTRAL OFFICE            | CO     |
| CHANGE                    | CHG    |
| CHECKPRINT                | CP     |
| CIRCLE                    | CIR    |

|  |       |
|--|-------|
| CULVERT  | CLVT  |
| CUT & RESTORE                                  | C&R   |
| DESIGNATION                                    | DESIG |
| DETAIL   | DET   |
| DIMENSION                                      | DIM   |
| DIRECTIONAL BORE                               | DB    |
| DITCH LINE                                     | D/L   |
| DRAWING  | DWG   |
| DRIVEWAY                                       | DRWY  |
| EAST   | E     |
| EDGE OF GRAVEL                                 | EOG   |
| EDGE OF HANDHOLE                               | EOH   |
| EDGE OF PAVEMENT                               | EOP   |
| EDGE OF ROAD                                   | EOR   |
| ELECTIC LINE-POWER LINE                        | E     |
| ENCASED  | ENC   |
| END LINK                                       | EL    |
| END OF CABLE                                   | EOC   |
| EQUATION                                       | EQ    |
| EQUIPPED WITH                                  | E/W   |
| EXAMPLE  | EX    |
| EXISTING QWEST COMMUNICATIONS CORPORATION, LLC | EQ    |
| EXTRA WORK DIRECTIVE                           | EWD   |
| FACE OF CURB                                   | FOC   |
| FIBER OPTIC CABLE                              | FOCA  |

|                              |        |
|------------------------------|--------|
| CITY BUILD                   | CB     |
| CITY RING                    | CR     |
| CONCRETE                     | CONC   |
| CONDUIT                      | CNDT   |
| CONFIGURATION                | CONFIG |
| CORRECTION                   | CORR   |
| CORRUGATED METAL PIPE        | CMP    |
| COUNTY                       | CTY    |
| COUNTY ROAD                  | CR     |
| COURT                        | CT     |
| HANDHOLE                     | HH     |
| HANDHOLE BUTTERFLY<br>DETAIL | HHBFD  |
| HIDDEN HANDHOLE              | HHH    |
| HIGH DENSITY<br>POLYETHYLENE | HDPE   |
| INFORMATION                  | INFO   |
| INNERDUCT                    | INDT   |
| INTERSTATE                   | I      |
| JOINT                        | JT     |
| LAST MILE                    | LM     |
| LATERAL                      | LAT    |
| LEADER                       | LDR    |
| LINE OF SIGHT                | LOS    |
| LINE TYPE SCALE              | LTS    |
| LINEWORK                     | LNWK   |
| LOCATION                     | LOCN   |
| LUCENT CABLE                 | LC     |
| MANHOLE                      | MH     |
| MANHOLE BUTTERFLY<br>DETAIL  | MHBFD  |
| MARKER                       | MKR    |
| MATCHLINE                    | ML     |
| MATERIAL                     | MAT    |
| MILE POST                    | MP     |
| MONTH/YEAR                   | MO/YR  |
| NO SPACE                     | NS     |
| NORTH                        | N      |
| NOT TO SCALE                 | NTS    |
| NOTE                         | NT     |

|                        |       |
|------------------------|-------|
| FITEL CABLE            | FC    |
| FOG LINE               | FOG   |
| FOOTAGE                | FTG   |
| GALVANIZED STEEL PIPE  | GSP   |
| GAS LINE               | G     |
| GRAY                   | GRY   |
| GREEN                  | GRN   |
| GROUND                 | GRD   |
| GUARDRAIL              | GR    |
| GUIDELINE              | GL    |
| POLYVINYL CHLORIDE     | PVC   |
| PRIVATE                | PVT   |
| PROJECT                | PROJ  |
| PROJECT WISE           | PW    |
| PROPERTY LINE          | PL    |
| PURPLE                 | PUR   |
| QUANTITY               | QTY   |
| RAILROAD               | R/R   |
| RED                    | R     |
| REDLINE                | RL    |
| REFERENCE              | REF   |
| RELOCATE               | RELOC |
| REMOVE                 | RMV   |
| REVISION               | REV   |
| RIGHT-OF-WAY           | R/W   |
| ROAD                   | RD    |
| ROUTE                  | RTE   |
| RUNNING LINE           | R/L   |
| SECTION                | SECT  |
| SEGMENT                | SEG   |
| SEICOR CABLE           | SC    |
| SEQUENTIAL             | SEQ   |
| SEWER LINE/STORM SEWER | S     |
| SHEET                  | SHT   |
| SIDEWALK               | SDWK  |
| SIGNAL WIRE            | SIG   |
| SLACK                  | SL    |

|                       |      |               |      |
|-----------------------|------|---------------|------|
| NUMBER                | #    | SOUTH         | S    |
| OBJECT                | OBJ  | SPACE         | SP   |
| OFFSET                | O/S  | SPLICE        | SPL  |
| ORANGE                | ORG  | STANDARDS     | STD  |
| ORIGINAL              | ORIG | STATE HIGHWAY | SH   |
| PIPELINE              | P    | STATE ROAD    | SR   |
| PIRELLI CABLE         | PC   | STATION       | STA  |
| POINT OF INTERSECTION | POI  | STEAM LINE    | STM  |
| POINT OF SWITCH       | PS   | STREET        | ST   |
|                       |      | SURGE BOX     | SB   |
| SWITCH                | SW   | UTILITY       | UTIL |
| TELEPHONE LINE        | T    | WATER LINE    | W    |
| TEXT                  | TXT  | WEST          | W    |
| TO                    | -    | WHITE         | WHT  |
| TRACK                 | TRK  | YELLOW        | YEL  |
| UNKNOWN               | UNKN |               |      |

### Customer Abbreviation Master List

| CURRENT NAME                 | OTHER NAMES | ABBREVIATION | REMARKS/COMMENTS |
|------------------------------|-------------|--------------|------------------|
| 360 NETWORKS                 | WFI         | 360          |                  |
| ACCENT COMMUNICATIONS        | -           | AC           |                  |
| ACSI                         | E-SPIRE     | ACSI         |                  |
| ADELPHIA                     | HYPERION    | ADEL         |                  |
| ADESTA                       | MFSNT       | ADES         |                  |
| ALLENS TV                    | -           | ALLEN        |                  |
| ALLTEL                       | -           | ALL          |                  |
| AMERICA ONLINE               | -           | AOL          |                  |
| AMERITECH                    | -           | AMERI        |                  |
| AMTRAK                       | -           | AMTK         |                  |
| AT&T                         | -           | ATT          |                  |
| ATG                          | -           | ATG          |                  |
| AXON                         | -           | AXO          |                  |
| BAY BRIDGE CONSORTIUM        | -           | BBC          |                  |
| BESTEL                       | -           | BEST         |                  |
| BURLINGTON NORTHERN R/R      | -           | BNRR         |                  |
| BURLINGTON NORTHERN SANTE FE | -           | BNSF         |                  |
| BUSINESS TELECOM             | -           | BTI          |                  |

|                                       |                          |                     |                         |
|---------------------------------------|--------------------------|---------------------|-------------------------|
| C3/AEP/ICG/CHOICECOM/CSW              | -                        | BTC                 |                         |
| CABLEONE                              | -                        | CBLONE              |                         |
| CAPROCK                               | MCLEOD                   | CAP                 |                         |
| CITIZENS COMMUNICATIONS               | -                        | CIT                 |                         |
| COGENT                                | -                        | COG                 |                         |
| CONRAIL R/R                           | -                        | CONR                |                         |
| CORVIS                                | -                        | CORV                |                         |
| CSX TRANSPORTATION, INC               | -                        | CSX                 |                         |
| DOMINION/VPS                          | -                        | DOM                 |                         |
| DQE                                   | -                        | DQE                 |                         |
| DTI                                   | -                        | DTI                 |                         |
| DUKENET                               | -                        | DUKE                |                         |
| <b>CURRENT NAME</b>                   | <b>OTHER NAMES</b>       | <b>ABBREVIATION</b> | <b>REMARKS/COMMENTS</b> |
| EL PASO NETWORKS                      | -                        | ELPASO              |                         |
| ENKIDO                                | -                        | ENKI                |                         |
| ENRON                                 | -                        | ENRON               |                         |
| ENTERGY                               | -                        | ENTER               |                         |
| FIBER TECHNOLOGIES                    | -                        | FTECH               |                         |
| FTV                                   | WILLIAMS                 | FTV                 |                         |
| GENUITY                               | GTE                      | GTE                 |                         |
| GEORGIA INDEPENDENT TELCO GROUP       | US CARRIER               | GITG                |                         |
| GLOBAL CROSSING                       | FRONTIER                 | GC                  |                         |
| GLOBAL METRO NETWORK                  | -                        | GMN                 |                         |
| GRANDE                                | -                        | GRAND               |                         |
| GUADALUPE                             | -                        | GUAD                |                         |
| GULF TELEPHONE                        | MADISON RIVER            | GULF                |                         |
| ICG TELECOM                           | -                        | ICG                 |                         |
| INTERPATH                             | PROGRESS/CARONET         | INTER               |                         |
| IXC                                   | BROADWING/THE DATA PLACE | IXC                 |                         |
| KENTUCKY DATA LINK                    | -                        | KDL                 |                         |
| LEVEL 3                               | -                        | LVLT                |                         |
| LOOKING GLASS                         | -                        | LOOKG               |                         |
| MASSACHUSETTS INSTITUTE OF TECHNOLOGY | -                        | MIT                 |                         |
| MCI                                   | -                        | MCI                 |                         |
| MCLEOD USA TELECOMMUNICATIONS         | -                        | MCLEOD              |                         |
| MEAG                                  | -                        | MEAG                |                         |

|                          |             |        |  |
|--------------------------|-------------|--------|--|
| METROMEDIA FIBER NETWORK | -           | MFN    |  |
| N AMERICAN DATA COMM     | -           | NADC   |  |
| NEON                     | -           | NEON   |  |
| NETWORK PLUS             | -           | NETP   |  |
| NORFOLK SOUTHERN R/R     | -           | NSRR   |  |
| ON FIBER                 | -           | ONFIB  |  |
| ONVOY                    | MEANS       | ONVOY  |  |
| PACBELL                  | -           | PACB   |  |
| PALMETTONET              | -           | PLMTO  |  |
| PATHNET                  | -           | PATH   |  |
| PEOPLES                  | -           | PEOP   |  |
| PF NET/VELOCITA          | -           | PFNET  |  |
| RCN TELECOM OF PA        | -           | RCN    |  |
| RCS DIGITAL SERVICES     | -           | RCS    |  |
| SACRAMENTO COUNTY        | -           | SAC    |  |
| SOUTHERN PACIFIC R/R     | -           | SPRR   |  |
| TELCOVE                  | -           | TLCV   |  |
| TELEGLOBE                | -           | TELEG  |  |
| TELERGY                  | -           | TELLER |  |
| TIME WARNER              | GST         | TW     |  |
| TIMING SOLUTIONS         | -           | TIMES  |  |
| TOUCH AMERICA            | -           | TOUCH  |  |
| UNION PACIFIC R/R        | -           | UPRR   |  |
| US SPRINT                | -           | SPT    |  |
| US WEST                  | -           | USW    |  |
| VALLEY                   | GRAND RIVER | VALLEY |  |
| WILLIAMS/AMERITECH       | -           | WILL   |  |
| WORLD WIDE FIBER         | 360 NTKW    | WWF    |  |
| WORLDCOMM                | BROOKS/MCI  | WCOM   |  |
| XCEL ENERGY              | -           | XCEL   |  |
| XO/NEXTLINK              | -           | XO     |  |
| ZEPHION                  | BBO         | ZEPH   |  |

## 47 Glossary

### Abutment

A wall supporting the end of a bridge and sustaining the pressure of the abutting earth

---

|                   |  |
|-------------------|--|
| Anchor            | A stationary device in the ground to which a Guy Wire is attached to support a pole  |
| Apron             | Protective material laid on a stream bed to prevent erosion at a culvert outlet, abutment, pier, and toe of a slope or similar location                            |
| ARP               | Armored Rodent Protection  |
| Ballast           | Gravel or broken stone laid in a railroad bed  |
| Bore              | To move ahead steadily against resistance in order to make a cylindrical hole  |
| BSP               | Black Steel Pipe   |
| Buried in Ballast | Conduit that has no brackets attaching it to a bridge structure, the conduit is simply buried within the ballast of a bridge                                       |
| Cable             | Fiber Optic Cable (For more definition see FOCA)   |
| Cable Marker      | A sign marking underground cable location  |
| Cable Sequentials | Physical markings on the cable, which represent either feet or meters. This will indicate linear length of cable   |
| Cat Plow          | To place HDPE with the use of a tracked or rubber tired tractor equipped with a plow shank and chute for opening a trench and disbursing the HDPE into the trench. |
| City Build        | See City Ring  |
| City Ring         | City Build and City Ring are the same. Rings are considered to be our Competitive Local Exchange (CLEC) side of telecommunications.                                |
| Concrete Cap      | To place concrete only on the top of HDPE, BSP, etc.   |
| Concrete Encased  | To encase concrete around HDPE, BSP, etc.  |
| Conventional Bore | Bores made with standard (auger) dry jack & dry bore equipment with the use of shoring boxes   |
| Core Bore         | The method of drilling through concrete type surfaces  |

---

|                  |  |
|------------------|--|
| CLEC             | Competitive Local Exchange Carrier – Companies that will compete on a selective basis for local exchange service, as well as long distance, internet access, and entertainment (e.g. Cable TV and Video on Demand). They will either build or lease local loops from the incumbent Local Exchange Carriers (LEC's) at wholesale rates for resale to end-users.   |
| Cyber Centers    | Sites through which, “CenturyLink Communications Corporation, LLC provides a full range of Web hosting and managed services for customers’ Internet-based applications”  |
| Dark Fiber       | Unused fiber through which no light is transmitted or installed fiber optic cable not carrying a signal. Sometimes dark fiber is sold by a carrier “CenturyLink Communications Corporation, LLC” without the (usually) accompanying transmission service. It’s “dark” because it’s sold without light communications transmission. The customer is expected to put his own electronics and signals on the fiber and make it light. |
| Dielectric Cable | Dielectric Cable is a non-conductive, non-metallic type of material.   |
| Directional Bore | This is a “trenchless” technology by use of a sophisticated bore equipment to cross under obstructions such as river crossings, lakes, canals, archaeological and ecological sites   |
| EOP              | Edge of Pavement   |
| FOCA             | Fiber Optic Cable – A technology in which light is used to transport information from one point to another. More specifically, fiber optics is thin filaments of glass through which light beams are transmitted over long distances carrying enormous amount of data.   |
| FOG              | Fog Line (the white line at the edge of a road to be utilized during extreme foggy conditions)   |
| Gap              | A break in continuity, or missing information  |
| GSP elements.    | Galvanized Steel Pipe - Typically use for in areas exposed to the  |
| Guardrail        | A barrier located along the edge of a roadway shoulder for the purpose of guiding errant vehicles onto the roadway.  |
| Headwall         | The portion of the bridge structure where the wingwall is attached and the bridge begins (directly supports the bridge structure).   |
| HDPE             | High Density Polyethylene  |

---



---

|                    |   |
|--------------------|---|
| IEC                | Interexchange Carrier – In practice, is a common carrier authorized by the FCC to carry customer transmissions between LATAs.   |
| ILEC               | Independent Local Exchange Carrier (i.e. GTE) Provides your <u>local</u> telephone service)   |
| Innerduct conduit. | <p>A conduit either corrugated or smooth that is pulled through other</p> <p>Corrugated innerduct is more flexible than smooth innerduct. Innerduct has thinner walls than HDPE. Innerduct is utilized to enhance the efficiency and improve space utilization of existing duct systems while maintaining the highest degree of protection for cable.</p> |
| Jack & Bore        | “See Conventional Bore”   |
| Last Mile          | In general it is conduit coming from the backbone or backbone facility connecting to a new or existing facility. Since the backbone is True-wave fiber the Last Mile will also be True-Wave.  |
| LATA               | Local Access and Transport Area – Geographical areas in the US within which a local telephone company may offer telecommunications service – local or long distance.  |
| LATERAL            | Connection from a Ring build to either an end office (Central Office) or Customer Premise.  |
| LEC                | Local Exchange Carriers – The local phone companies, which can be either a Bell Operating Company (BOC) or an independent (i.e. GTE) which provide local transmission services. Prior to divestiture the LECs were called telephone companies or Telcos. (LECs provides your local telephone service)   |
| Offset HDPE        | The linear distance (dimension) from a baseline to an object, or the  |
| Overpass           | A man made structure conveying traffic over a railroad or other roadway.  |
| POP                | Point of Presence – POP is the place your long-distance carrier terminates your long distance lines just before those lines are connected to your local phone company's lines. The point where the Independent Exchange Carrier (IEC) and the Local Exchange Carrier (LEC) are interconnected   |
| PVC                | Conduit made of Polyvinyl Chloride - Used for encased and directed burial applications of communication systems   |

|                  |  |
|------------------|--|
| Rail Plow        | To place HDPE with the use of a railroad car customized with a plow shank and chute for opening a trench and disbursing the HDPE into the trench |
| Range            | A division of territory. One of the rows in U.S. public-land survey that are numbered east and west from the principal meridian of the survey    |
| Regen            | Is a building that houses a device or system used to increase transmission signal strength   |
| Retaining Wall   | A wall for sustaining the pressure of earth or other types of fill   |
| R/W or ROW       | The legal right of passage over specific ground  |
| Running Line     | The path that a cable or conduit follows including its meanderings   |
| Section          | A piece of land one square mile in area forming one of the 36 subdivisions of a township   |
| Segment          | Geographical boundaries within a span  |
| Sheet Continuity | All alignment must match from one sheet to another   |
| Siding Track     | A track extending away & parallel from the main track, however, returning to the main track  |
| Span             | The geographical boundary between two equipment termination points (Regens)  |
| Splice point     | The point at which two or more cables are joined, the physical connection of fibers in a fiber optic cable                                       |
| Spur Track       | A track extending away from the main track and not returning   |

## 48 References

| Reference                                     | Link | Description   |
|---|------|---|
| AutoCAD Setup Instructions Manual             |      | Installation instructions of CTL AC blocks, Lisp, net application, plot and line styles |
| CenturyLink Drawing Standards Overview Manual |      | Overview of the drafting standards and system requirements                              |
| LISP Programs Reference Manual                |      | LISP References   |

---

## 49 Version History

The latest version of this document can be found at:

Electronic copies in any location other than the link accessed above and all printed copies are uncontrolled.

| <b>Version</b> | <b>Date Published</b> | <b>Business Process Owner (Region)</b> | <b>Document Writer</b> | <b>Summary of Changes</b> |
|----------------|-----------------------|--|------------------------|---------------------------|
| 1.0            | 9/5/2018              | Heather Seabury                        | Heather Seabury        | First publication         |